

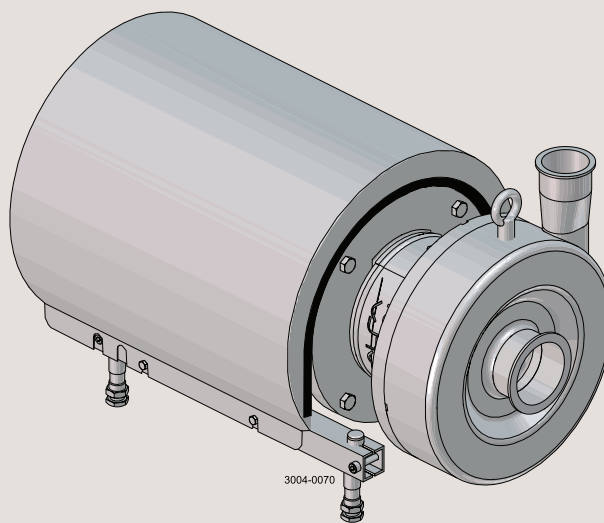

# Instruction Manual

## LKHPF Filtration Centrifugal Pump for High Inlet Pressure



ESE01950-EN12 2022-10

Original manual



# Table of contents

The information herein is correct at the time of issue but may be subject to change without prior notice

<b>1. Declarations of Conformity</b>	<b>4</b>
<b>2. Safety</b>	<b>6</b>
2.1. Important information	6
2.2. Warning signs	7
2.3. Safety precautions	8
<b>3. Installation</b>	<b>10</b>
3.1. Unpacking/delivery	10
3.2. Installation	12
3.3. Pre-use check - pump without impeller screw	19
3.4. Pre-use check - pump with impeller screw	21
3.5. Recycling information	22
<b>4. Operation</b>	<b>23</b>
4.1. Operation/Control	23
4.2. Troubleshooting	25
4.3. Recommended cleaning	26
<b>5. Maintenance</b>	<b>27</b>
5.1. General maintenance	27
5.2. Cleaning procedure	29
5.3. Dismantling of pump/shaft seals	30
5.4. Assembly of pump/shaft seal	34
<b>6. Technical data</b>	<b>39</b>
6.1. Technical data	39
6.2. Relubrication intervals	40
6.3. Torque specifications	40
6.4. Weight (kg)	41
6.5. Noise emission	42
<b>7. Parts list and service kits</b>	<b>43</b>
7.1. LKHPF Filtration centrifugal pump for high inlet pressure	43
7.2. LKHPF - Wet end	44
7.3. LKHPF - Motor-dependent parts	46
7.4. LKHPF - Shaft seals	48

# 1 Declarations of Conformity

## EU Declaration of Conformity

The Designated Company

Alfa Laval Kolding A/S, Albuen 31, DK-6000 Kolding, Denmark, +45 79 32 22 00

Company name, address and phone number

Hereby declare that

Pump

Designation

LKHPF-10, LKHPF-20, LKHPF-25, LKHPF-35, LKHPF-40, LKHPF-45, LKHPF-50, LKHPF-60, LKHPF-70

Type

Serial number from 10.000 to 1.000.000

is in conformity with the following directives with amendments:

- Machinery Directive 2006/42/EC
- RoHS EU Directive 2011/65/EU and amendments

The person authorised to compile the technical file is the signer of this document.

Global Product Quality Manager

Title

Lars Kruse Andersen

Name

Kolding, Denmark

Place

2022-10-01

Date (YYYY-MM-DD)

Signature

This Declaration of Conformity replaces Declaration of Conformity dated 2022-05



# 1 Declarations of Conformity

## UK Declaration of Conformity

The Designated Company

Alfa Laval Kolding A/S, Albuen 31, DK-6000 Kolding, Denmark, +45 79 32 22 00

Company name, address and phone number

Hereby declare that

Pump

Designation

LKHPF-10, LKHPF-20, LKHPF-25, LKHPF-35, LKHPF-40, LKHPF-45, LKHPF-50, LKHPF-60, LKHPF-70

Type

Serial number from 10.000 to 1.000.000

is in conformity with the following directives with amendments:

- The Supply of Machinery (Safety) Regulations 2008
- The Restriction of the Use of Certain Hazardous Substances in Electrical and Electronic Equipment Regulations 2012

Signed on behalf of: Alfa Laval Kolding A/S

Global Product Quality Manager

Title

Lars Kruse Andersen

Name

Kolding, Denmark

Place

2022-10-01

Date (YYYY-MM-DD)

Signature

DoC Revison\_02\_102022

**UK  
CA**



## 2 Safety

---

*Unsafe practices and other important information are emphasised in this manual.  
Warnings are indicated by means of special signs.  
**Always read the manual before using the pump!***

---

### 2.1 Important information

---

#### **WARNING**

Indicates that special procedures must be followed to avoid serious personal injury.

#### **CAUTION**

Indicates that special procedures must be followed to avoid damage to the pump.

#### **NOTE**

Indicates important information to simplify or clarify procedures.

---

This Instruction manual is designed to provide the user with the information to perform tasks safely for all phases in the life time of the product supplied.

The User shall always read the safety section first. Hereafter the User can skip to the relevant section for the task to be carried out or for the information needed.

This is the complete manual for the supplied product.

Skills for personal:

Operators:

The operators shall read and understand the instruction manual for the supplied product

Maintenance personnel:

The maintenance personnel shall read and understand the instruction manual.

The maintenance personnel or technicians shall be skilled within the field required to carry out the maintenance work safely.

Trainees:

Trainees can perform tasks under the supervision of an experienced employee.

People in general:

The public shall not have access to the supplied product.

---

#### **How to contact Alfa Laval**

Contact details for all countries are continually updated on our website.

Please visit [www.alfalaval.com](http://www.alfalaval.com) to access the information directly.

---

---

*Unsafe practices and other important information are emphasised in this manual.  
Warnings are indicated by means of special signs.  
Always read the manual before using the pump!*

---

### 2.2 Warning signs

---

General warning:



Dangerous electrical voltage:



Caustic agents:



## 2 Safety

---

All warnings in the manual are summarised on this page.

Pay special attention to the instructions below so that serious personal injury and/or damage to the pump are avoided.

---

### 2.3 Safety precautions

---

#### General

**Always** ensure that personnel must have experience with lifting operations.

**Always** ensure the lifting point to be in line with center of gravity. Adjust lifting point if necessary.

**Always** keep an eye on the load and stay clear during the lifting operation.

**Always** ensure that the lifting equipment is suitable for the specific pump.

**Always** use appropriate lifting equipment for heavy parts when relevant. Use lifting logs when applied.

To prevent unexpected start and contact with electrical live and moving parts.

**Always** disconnect the power supply safely:

- The power supply disconnecting device must be disconnected (in off position) and locked.

- In case the pump is capable of being plugged into an electrical supply, removal of the plug is sufficient, provided that the operator can check from any of the points to which he has access that the plug remains removed.

**Always** refer to the motor instruction manual for installation and maintenance of the motor.

**Never** touch the impeller through the inlet/outlet during start/stop as this can cause serious injury.

---

#### Installation:

**Always** read the technical data thoroughly. (See chapter 6 Technical data)



#### Pump without impeller screw:

**Always** remove the impeller before checking the direction of rotation.

**Never** start the pump if the impeller is fitted and the pump casing is removed.

#### Pump with Impeller screw:

**Never** start in the wrong direction of rotation with liquid in the pump.

**Always** have the pump electrically connected by authorised personnel. (See the motor instruction)



#### Operation:

**Always** read the technical data thoroughly. (See chapter 6 Technical data)

**Never** touch the pump or the pipelines when pumping hot liquids or when sterilising.

**Never** run the pump with both the suction side and the pressure side blocked.

**Never** run the pump when partially installed or not completely assembled.



**Necessary** precautions must be taken if leakage occurs as this can lead to hazardous situations.

**Always** handle lye and acid with great care.

**Never** use the pump for products not mentioned in the Alfa Laval pump selection program.

The Alfa Laval pump selection program can be acquired from your local Alfa Laval sales company.



#### Maintenance:

**Always** read the technical data thoroughly. (See chapter 6 Technical data)

**Never** service the pump when it is hot.

**Never** service the pump if pressurised.

**Always** use Alfa Laval genuine spare parts.



#### Motors with grease nipples:

**Always** lubricate according to motor manufacturer's recommended procedures.

**Always** locate and remove grease vent plugs, if provided, prior to adding grease.

**Always** check motor nameplate for grease type and lubrication intervals.





*All warnings in the manual are summarised on this page.*

*Pay special attention to the instructions below so that serious personal injury and/or damage to the pump are avoided.*

---

### Transportation:

#### **Transportation of the pump or the pump unit:**

**Never** lift or elevate in any way other than described in this manual

**Always** drain the pump head and accessories of any liquid

**Always** ensure that no leakage of lubricants can occur

**Always** transport the pump in its upright position

**Always** ensure that the unit is securely fixed during transportation

**Always** use the original packaging or similar during transportation

**Always** use suitable transport device ie. forklift or pallet lifter

---

### Storage:

Ideally as a guide Alfa Laval would recommend:

- Store supplied product as supplied in original packaging
  - Port opening should be protected against any ingress
  - Bare steel (not stainless) should be lightly oiled/greased
  - Store in a clean, dry place without direct sunlight or UV light
  - Temperature range -5 to 40°C
  - Relative humidity less than 60%
  - No exposure to corrosive substances (also air contained)
-

## 3 Installation

---

### 3.1 Unpacking/delivery

---

#### Step 1

Always use a lifting crane when handling the pump (see technical data).

#### CAUTION

Alfa Laval cannot be held responsible for incorrect unpacking.

#### WARNING:

Be aware that certain pump configurations can tilt, and thereby cause injuries to feet or fingers. The pump should be supported underneath the adaptor, when not installed in the process line.

---

#### Check the delivery for:

1. Complete pump.
2. Delivery note.
3. Motor instructions.

#### Step 2

Remove any packing materials from the inlet and the outlet.  
Avoid damaging the inlet and the outlet.  
Avoid damaging the connections for flushing liquid, if supplied.

\* Remove packing materials

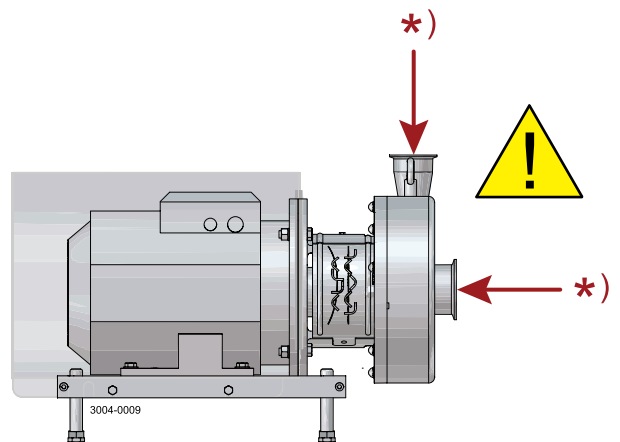

#### Step 3

Inspect the pump for visible transport damage.

\* Inspect for visible damage

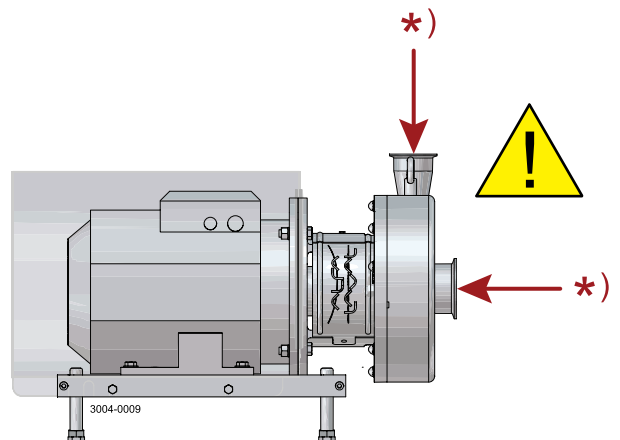

#### Step 4

Always remove the shroud, if fitted, before lifting the pump.

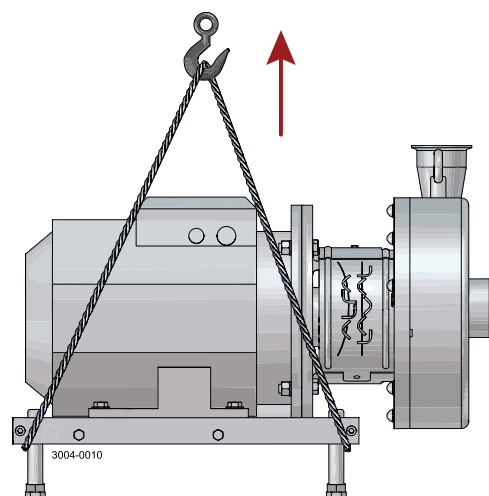

## 3 Installation

---

Read the instructions carefully and pay special attention to the warnings! Always check the pump before operation.

- See the pre-use check in section 3.3 Pre-use check - pump without impeller screw.

The larger pumps sizes are very heavy. Alfa Laval therefore recommends the use of a lifting crane when handling the pump.

---

### 3.2 Installation

---

#### Step 1



**Always** read the technical data thoroughly. (See chapter 6 Technical data)



**Always** use a lifting crane when handling the pump. (See chapter 6 Technical data)



**Always** have the pump electrically connected by authorised personnel. (see the motor instructions).

#### CAUTION

Alfa Laval cannot be held responsible for incorrect installation.

#### CAUTION

The pump does not prevent back flow when intentionally or unintentionally stopped. If back flow can cause any hazardous situations, precautions must be taken e.g. check the valve to be installed in the system preventing hazardous situations from arising.

#### CAUTION

If the pump has been stored for longer period of time there is a risk that the seal faces may stick together and consequently cause damage to the seal at start-up. Please ensure that the pump shaft can be rotated by hand before start-up.

#### WARNING:

Alfa Laval recommends the supply disconnecting device shall be in accordance with EN60204-1. Always disconnect the supply disconnecting device safely after installation before continuing the installation.

---

#### Step 2

Ensure that there is sufficient clearance around the pump (min. 0.5 m) (1.64").

Ensure the floor/frame is able to support the weight of the pump. See Technical data and other environment requirements in section 6.

Ensure the pump is supported by all four feet equally.

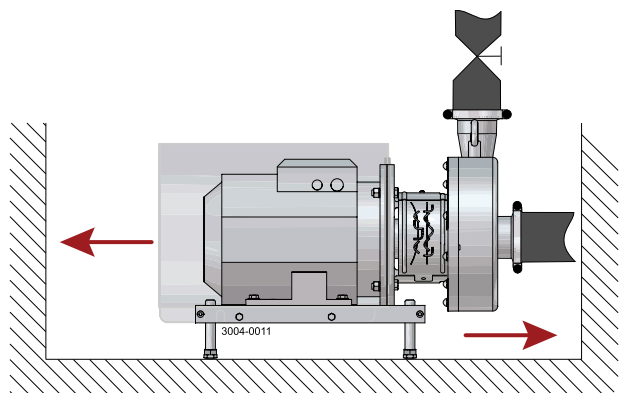

## 3 Installation

Read the instructions carefully and pay special attention to the warnings! Always check the pump before operation.

- See the pre-use check in section 3.3 Pre-use check - pump without impeller screw.

The larger pumps sizes are very heavy. Alfa Laval therefore recommends the use of a lifting crane when handling the pump.

### Step 3

Check that the flow direction is correct.

O: Outlet

I: Inlet

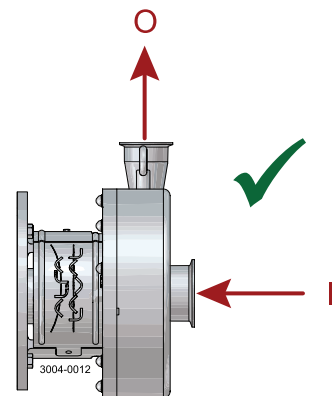

### Step 4

1. Ensure that the pipelines are routed correctly.
2. Ensure that the connections are tight.
3. Remember seal rings. Few bends.

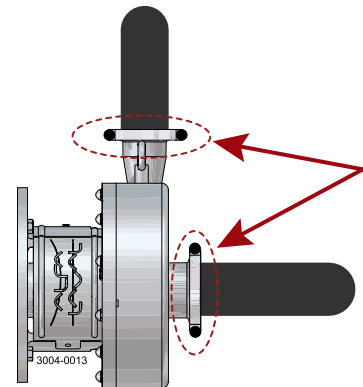

### Step 5

**Avoid stress on the pump.**

**Piping system must be self-supported.**

**Pay special attention to:**

- Vibrations.
- Thermal expansion of the tubes.
- Excessive welding.
- Overloading of the pipelines.

Example of piping system self-supported.

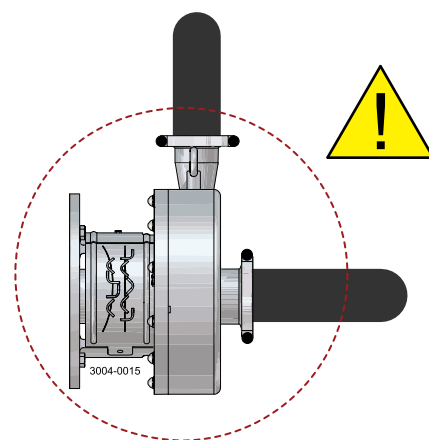
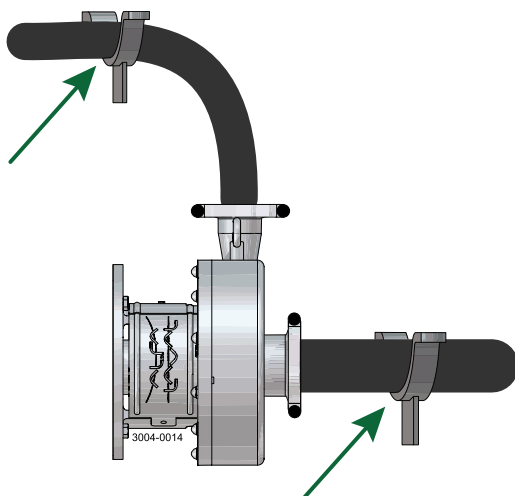

### 3 Installation

Read the instructions carefully and pay special attention to the warnings! Always check the pump before operation.  
- See the pre-use check in section 3.3 Pre-use check - pump without impeller screw.  
The larger pumps sizes are very heavy. Alfa Laval therefore recommends the use of a lifting crane when handling the pump.

#### Step 6

Ensure correct alignment of pump inlet and outlet with piping system.

Alignment can be done by adjusting the pump legs.

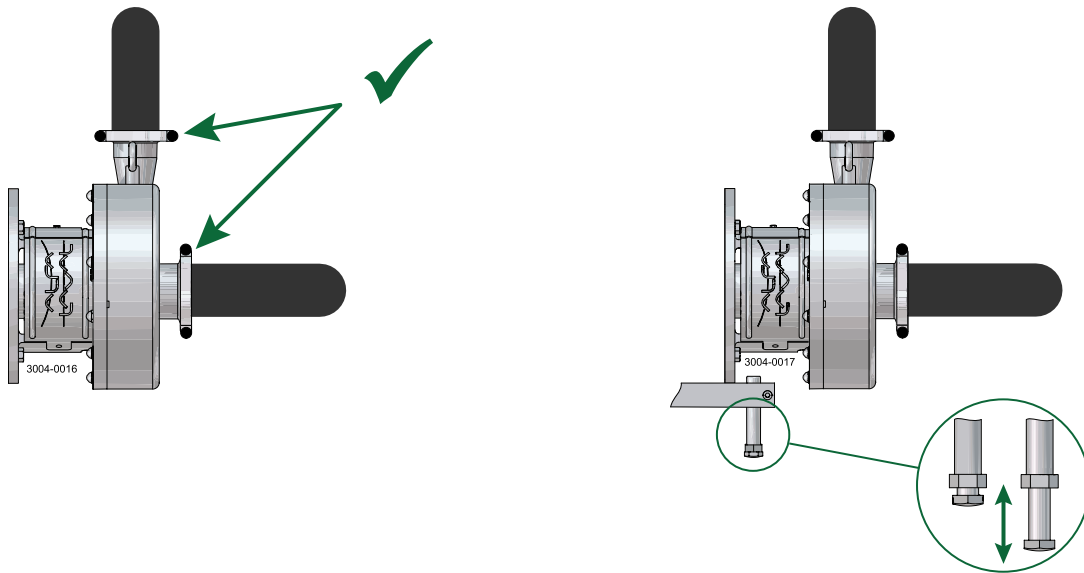

Centre of inlet and outlet to be aligned with centre of piping system.

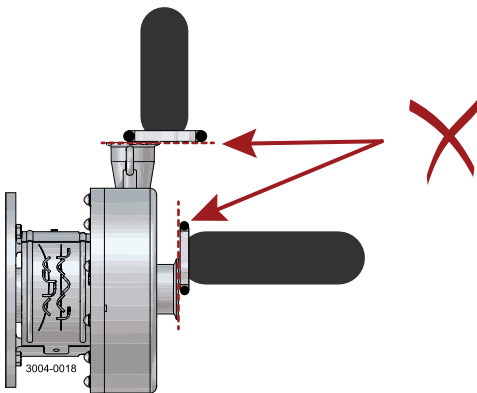

### 3 Installation

Read the instructions carefully and pay special attention to the warnings! Always check the pump before operation.

- See the pre-use check in section 3.3 Pre-use check - pump without impeller screw.

The larger pumps sizes are very heavy. Alfa Laval therefore recommends the use of a lifting crane when handling the pump.

No gaps between connections on pump inlet and inlet pipe, and pump outlet and outlet pipe.

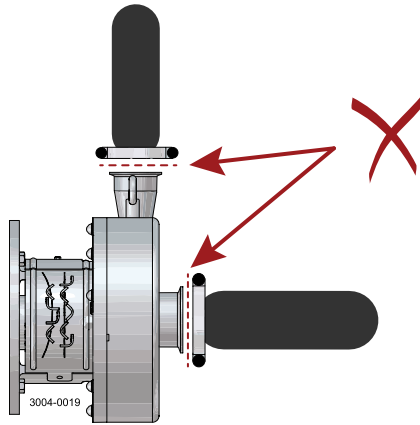

Angle between connections on pump inlet and inlet pipe, pump outlet and outlet pipe not allowed.

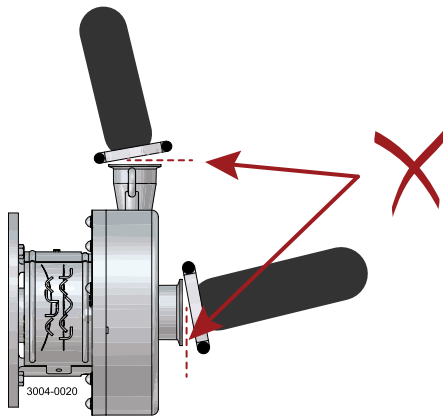

Ensure correct alignment of pump casing and pump backplate. Angle not allowed. Alignment can be done by adjusting the pump legs.

### 3 Installation

Read the instructions carefully and pay special attention to the warnings! Always check the pump before operation.

- See the pre-use check in section 3.3 Pre-use check - pump without impeller screw.

The larger pumps sizes are very heavy. Alfa Laval therefore recommends the use of a lifting crane when handling the pump.

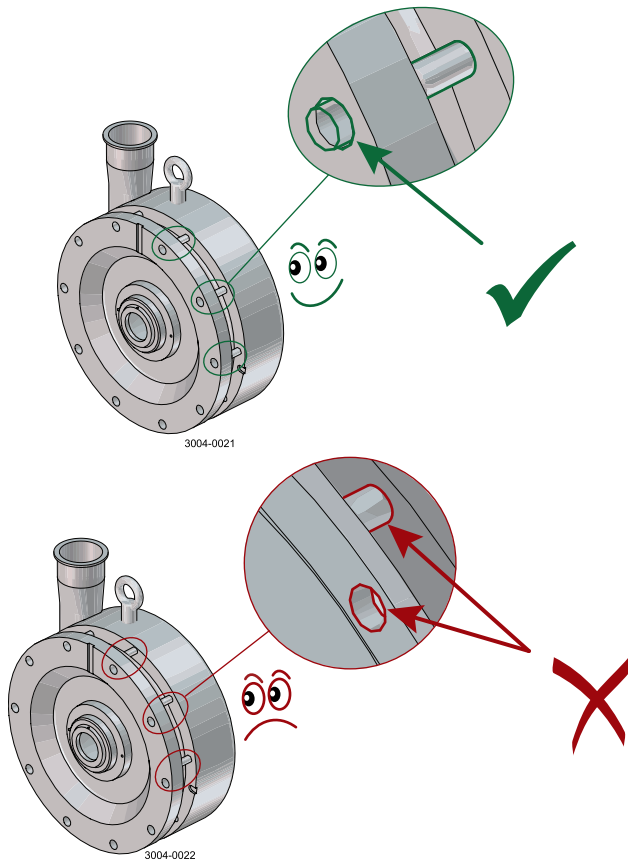

Ensure stud bolts in casing are aligned with holes in backplate.



## 3 Installation

Read the instructions carefully and pay special attention to the warnings! Always check the pump before operation.

- See the pre-use check in section 3.3 Pre-use check - pump without impeller screw.

The larger pumps sizes are very heavy. Alfa Laval therefore recommends the use of a lifting crane when handling the pump.

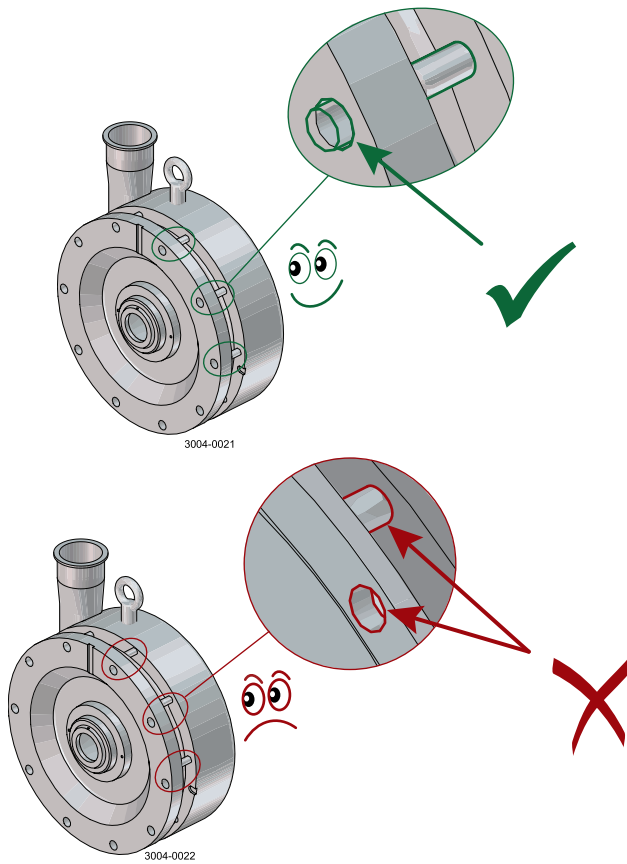

### Note

In case of shaft seal leakage, the media will drip from the slot in the bottom of the adaptor. In case of shaft seal leakage, Alfa Laval recommends putting a drip tray underneath the slot to collect the leakage.

### 3 Installation

---

*Read the instructions carefully and pay special attention to the warnings! Always check the pump before operation.*

*- See the pre-use check in section 3.3 Pre-use check - pump without impeller screw.*

*The larger pumps sizes are very heavy. Alfa Laval therefore recommends the use of a lifting crane when handling the pump.*

---

Always ensure the adaptor shield and motor fan guard are present and mounted correctly and allow no access to rotating parts before installing and starting the pump.

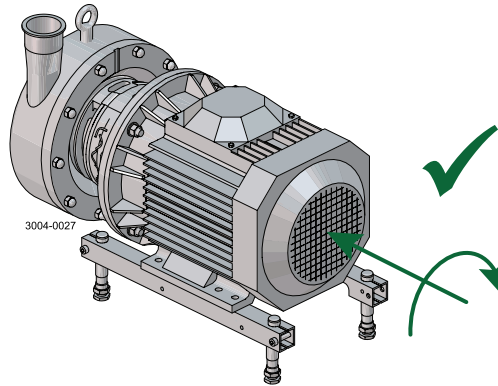

Study the instructions carefully and pay special attention to the warnings!  
 LKH-5 to LKH-60 are supplied without impeller screw as standard but this can be supplied.  
 Check the direction of rotation of the impeller before operation.  
 - See the indication label on the pump.

### 3.3 Pre-use check – pump without impeller screw

#### Step 1 Pump without impeller screw



**Always** remove the impeller before checking the direction of rotation.



**Never** start the pump if the impeller is fitted and the pump casing is removed.

1. Remove cap nuts (28), washers (29) and pump casing (45).
2. Remove impeller (39) (see also the instruction in section 5.4 Assembly of pump/shaft seal).

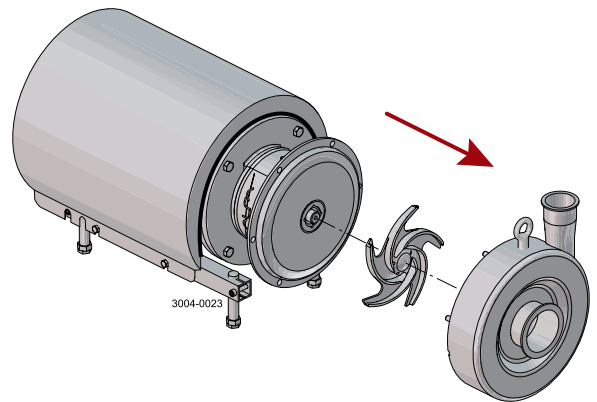

#### Step 2

**Warning:** Stay clear and ensure no one is near the shaft during test of rotation.

1. Connect power supply.
2. Start and stop the motor momentarily.
3. Ensure that the direction of rotation of the stub shaft (9) is anti-clockwise as viewed from the inlet side.
4. Disconnect power supply safety.

\* Stub shaft

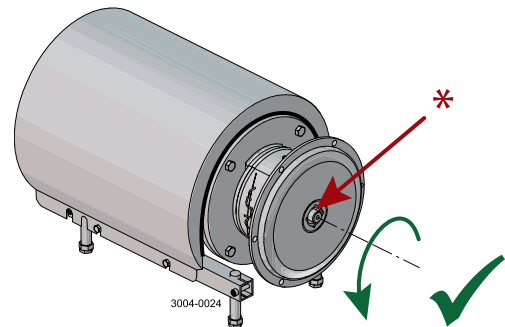

#### Step 3

Fit and tighten impeller (39).

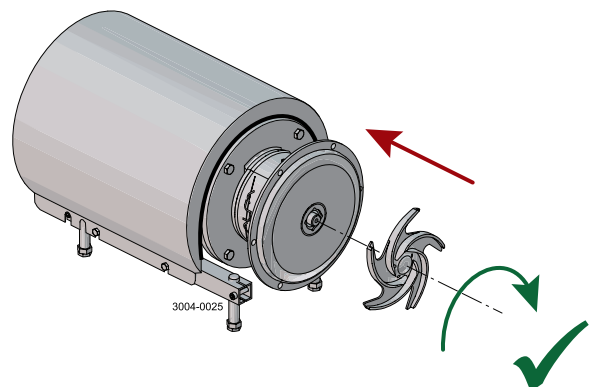

### 3 Installation

---

*Study the instructions carefully and pay special attention to the warnings!*

*LKH-5 to LKH-60 are supplied without impeller screw as standard but this can be supplied.*

*Check the direction of rotation of the impeller before operation.*

*- See the indication label on the pump.*

---

#### **Step 4**

1. Fit pump casing (45).
2. Fit washers (29) and cap nuts (28) and tighten.

Note: Cap nuts must be tightened according to the torque values specified in section 6 Technical data

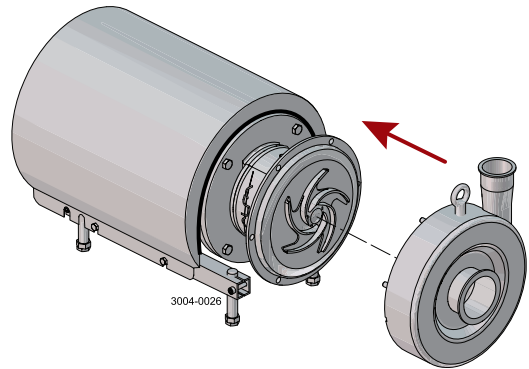

---

Study the instructions carefully and pay special attention to the warnings!  
LKH-5 to LKH-60 are supplied without impeller screw as standard but this can be supplied.  
Check the direction of rotation of the impeller before operation.  
- See the indication label on the pump.

---

### 3.4 Pre-use check – pump with impeller screw

---

**Never** start in the wrong direction of rotation with liquid in the pump.

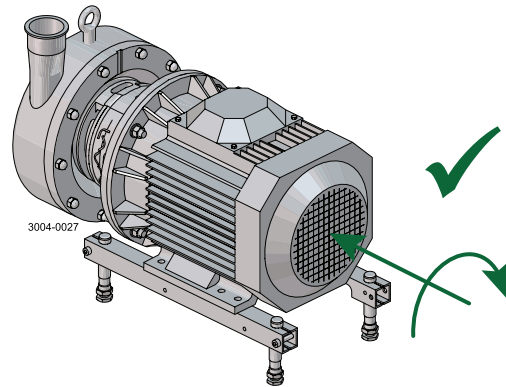

1. Connect power supply
2. Start and stop the motor momentarily.
3. Ensure that the direction of rotation of the motor fan is clockwise as viewed from the rear end of the motor.
4. Disconnect power supply safely

View from rear  
end of motor

## 3 Installation

---

### 3.5 Recycling information

---

- **Unpacking**

- Packing material consists of wood, plastics, cardboard boxes and in some cases metal straps.
- Wood and cardboard boxes can be re-used, recycled or used for energy recovery.
- Plastics should be recycled or burnt at a licensed waste incineration plant.
- Metal straps should be sent for material recycling.

- **Maintenance**

- During maintenance, oil and wearing parts in the machine are replaced.
- All metal parts should be sent for material recycling.
- Worn out or defective electronic parts should be sent to a licensed handler for material recycling.
- Oil and all non-metal wearing parts must be disposed of in accordance with local regulations.

- **Scrapping**

- At the end of use, the equipment must be recycled according to the relevant, local regulations. Besides the equipment itself, any hazardous residues from the process liquid must be considered and disposed of in a proper manner. When in doubt, or in the absence of local regulations, please contact your local Alfa Laval sales company.
-

Read the instructions carefully and pay special attention to the warnings!

4.1 Operation/Control

Step 1



**Always** read the technical data thoroughly. See chapter 6 Technical data

**CAUTION**  
Alfa Laval cannot be held responsible for incorrect operation/control.

Step 2



**Never** touch the pump or the pipelines when pumping hot liquids or when sterilising.

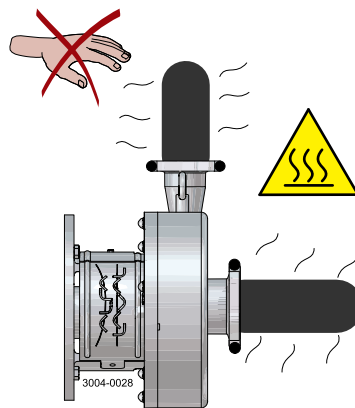

Step 3



**Never** run the pump with both the suction side and the pressure side blocked.

**Danger of explosion!**

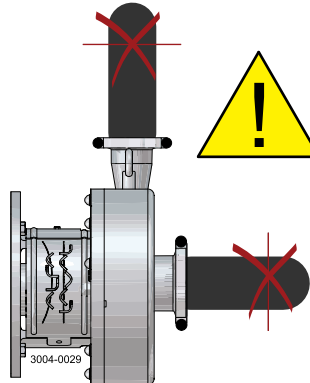

## 4 Operation

Read the instructions carefully and pay special attention to the warnings!

### Step 4

**CAUTION**  
The shaft seal must not run dry.

**CAUTION**  
**Never** throttle the inlet side.

\* Do not allow to run dry

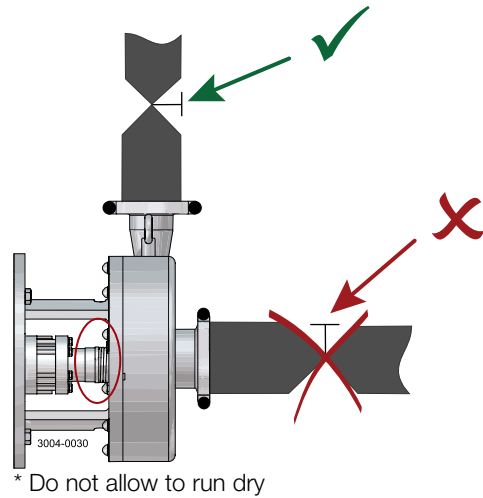

### Step 5

**Flushed shaft seal:**  
1. Connect the inlet of the flushing liquid correctly (ø6 tube).  
2. Regulate the water supply correctly.  
3. Observe the steam data.

O: Outlet  
I: Inlet

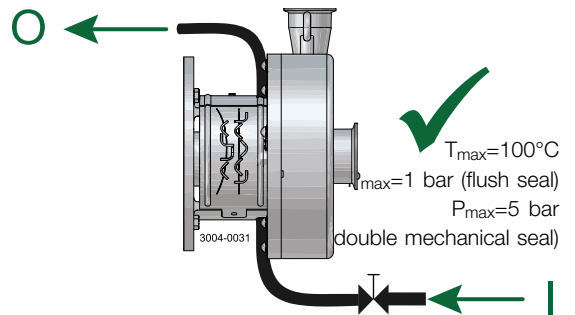

### Step 6

**Control:**  
Reduce the capacity and the power consumption by means of:

- Reducing the impeller diameter.
- Reducing the speed of the motor.

\* Throttling the pressure side of the pump.

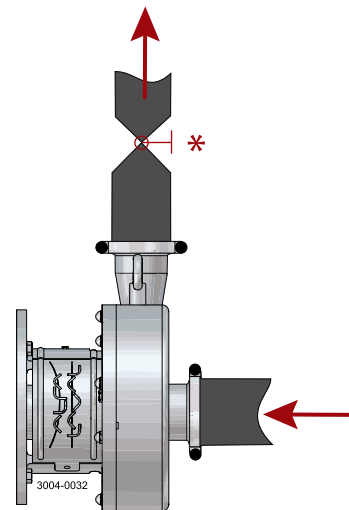



*Pay attention to possible faults.  
Read the instructions carefully.*

## 4.2 Troubleshooting

### NOTE!

Study the maintenance instructions carefully before replacing worn parts. - See section 5.1 General maintenance

Problem	Cause/result	Remedy
Overloaded motor	<ul style="list-style-type: none"> <li>- Pumping of viscous liquids</li> <li>- Pumping of high density liquids</li> <li>- Low outlet pressure (counter pressure)</li> <li>- Lamination of precipitates from the liquid</li> </ul>	<ul style="list-style-type: none"> <li>- Larger motor or smaller impeller</li> <li>- Higher counter pressure (throttling)</li> <li>- Frequent cleaning</li> </ul>
Cavitation: <ul style="list-style-type: none"> <li>- Damage</li> <li>- Pressure reduction (sometimes to zero)</li> <li>- Increase in noise level</li> </ul>	<ul style="list-style-type: none"> <li>- Low inlet pressure</li> <li>- High liquid temperature</li> </ul>	<ul style="list-style-type: none"> <li>- Increase the inlet pressure</li> <li>- Reduce the liquid temperature</li> <li>- Reduce the pressure drop before the pump</li> <li>- Reduce speed</li> </ul>
Leaking shaft seal	<ul style="list-style-type: none"> <li>- Dry run</li> <li>- Incorrect rubber grade</li> <li>- Abrasive particles in the liquid</li> </ul>	Replace: All wearing parts  If necessary: <ul style="list-style-type: none"> <li>- Change rubber grade</li> <li>- Select stationary and rotating seal ring in silicon carbide/silicon carbide</li> </ul>
Leaking O-ring seals	Incorrect rubber grade	Change rubber grade

## 4 Operation

The pump is designed for cleaning in place (CIP). CIP = Cleaning In Place.  
Read the instructions carefully and pay special attention to the warnings!  
NaOH = Caustic soda.  
HNO<sub>3</sub> = Nitric acid.

### 4.3 Recommended cleaning

#### Step 1



**Always** handle lye and acid with great care.  
**Always** follow the instructions in the safety data sheet for the cleaning agent.

**Danger, caustic!**



Always wear rubber gloves!



Always wear protective goggles!

#### Step 2



**Never** touch the pump or the pipelines when sterilising.

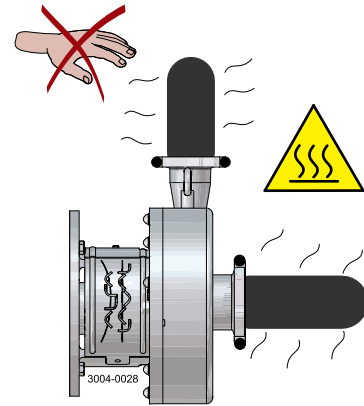

#### Step 3

**Examples of cleaning agents:** Use clean water, free from chlorides.  
1. 1% by weight NaOH at 70°C (158°F).

1 kg (2.2 lb) NaOH	+	100 l (26.4 gal) water	= Cleaning agent.
-----------------------	---	---------------------------	-------------------

2.2 l (0.6 gal) 33% NaOH	+	100 l (26.4 gal) water	= Cleaning agent.
-----------------------------	---	---------------------------	-------------------

2. 0.5% by weight HNO<sub>3</sub> at 70°C (158°F).

0.7 l (0.2 gal) 53% HNO <sub>3</sub>	+	100 l (26.4 gal) water	= Cleaning agent.
---	---	---------------------------	-------------------

1. Avoid excessive concentration of the cleaning agent  
⇒ Dose gradually!
2. Adjust the cleaning flow to the process.  
Sterilisation of milk/viscous liquids  
⇒ Increase the cleaning flow!

#### Step 4



**Always** rinse well with clean water after using a cleaning agent.

#### NOTE

The cleaning agents must be stored/disposed of in accordance with current regulations/directives.

#### NOTE:

If pumps are sterilised using steam, standard 3A requires the process system to be designed to automatically shut down if the product pressure in the system becomes less than that of the atmosphere and it cannot be started until the system is re-sterilised.

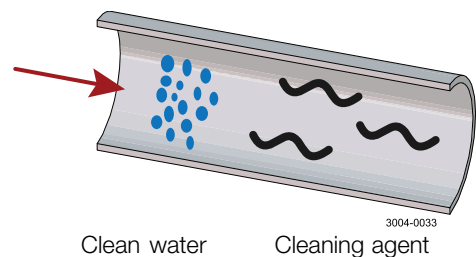

Clean water

Cleaning agent

Maintain the pump carefully. Read the instructions carefully and pay special attention to the warnings!  
 Always keep spare shaft seals and rubber seals in stock.  
 See separate motor instructions.  
 Check the pump for smooth operation after service.

### 5.1 General maintenance

#### Step 1



**Always** read the technical data thoroughly. (See chapter 6 Technical data)



**Always** disconnect the power supply when servicing the pump.

**NOTE:** All scrap must be stored/discharged in accordance with current rules/directives.

#### Step 2



**Never** service the pump when it is hot.

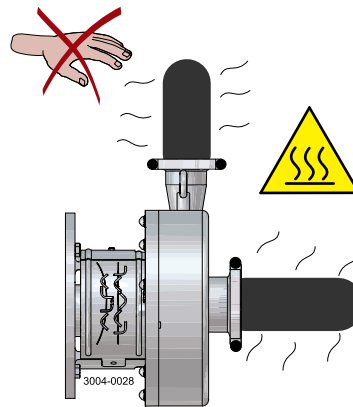

#### Step 3



**Never** service the pump with the pump and pipelines under pressure.

**CAUTION**  
 Fit the electrical connections correctly if they have been removed from the motor during service.

**CAUTION**  
 Pay special attention to the warnings!

\* Atmospheric pressure required!

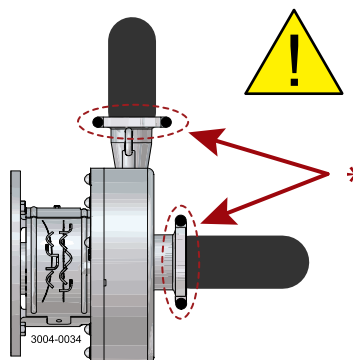

#### Step 4

**Recommended spare parts:** Order service kits from the service kits list (see chapter 7 Parts list and service kits).

**Ordering spare parts:** Contact your local Alfa Laval sales company.

**Note:** If the pump is supplied with FEP O-rings, Alfa Laval recommends replacing the casing O-ring during pump maintenance.

## 5 Maintenance

*Maintain the pump carefully. Read the instructions carefully and pay special attention to the warnings!*

*Always keep spare shaft seals and rubber seals in stock.*

*See separate motor instructions.*

*Check the pump for smooth operation after service.*

### Safety check

A visual inspection of adaptor shield and motor fan guard must be carried out every 12 months.

If loss or damage to shield or guard, especially when this leads to deterioration of safety performance, it shall be replaced.

The fixing of shield and guards should only be replaced with fixings of the same or an equivalent type.

### Inspection acceptance criteria:

- It is not possible to reach the shaft or fan
- The shield and guard must be securely mounted
- Ensure that the screws are tightened

### Procedure in case of non-acceptance:

- Fix and/or replace the shield or guard.

NOTE! Read the maintenance instructions carefully before replacing worn parts. - See section 5.1 General maintenance

	Shaft seal	Rubber seals	Motor bearings
Preventive maintenance	<b>Replace after 12 months:</b> (one-shift) Complete shaft seal	Replace when replacing the shaft seal	
Maintenance after leakage (leakage normally starts slowly)	<b>Replace at the end of the day:</b> Complete shaft seal	Replace when replacing the shaft seal	
Planned maintenance	<ul style="list-style-type: none"> <li>- Regular inspection for leakage and smooth operation</li> <li>- Keep a record for the pump</li> <li>- Use the statistics for inspection planning purposes</li> </ul> <b>Replace after leakage:</b> Complete shaft seal	Replace when replacing the shaft seal	Annual inspection is recommended <ul style="list-style-type: none"> <li>- Replace complete bearing if worn</li> <li>- Ensure that the bearing is axially locked (See motor instructions)</li> </ul>
Lubrication	<b>Before fitting</b> Lubricate the O-rings with silicone grease or silicone oil	<b>Before fitting</b> Silicone grease or silicone oil	See section 6.2 Relubrication intervals

### Pre-use check

#### CAUTION!

Fit the electrical connections correctly if they have been removed from the motor during service. (See 3.3 Pre-use check - pump without impeller screw).

#### Pay special attention to warnings!

1. Start and stop the motor momentarily
2. Ensure that the pump operates smoothly.

*Maintain the pump carefully. Read the instructions carefully and pay special attention to the warnings!*  
*Always keep spare shaft seals and rubber seals in stock.*  
*See separate motor instructions.*  
*Check the pump for smooth operation after service.*

---

### 5.2 Cleaning procedure

---

#### **Cleaning procedure for soiled impeller screw tapped hole:**

**Warning:** Always follow the instructions in the safety data sheet for the cleaning agent.

1. Remove stub shaft (9) in accordance with section 5.3 of the Service manual.
2. Submerge and soak the stub shaft for 5 minutes in COP tank with 2% caustic wash
3. Scrub the blind tapped impeller screw hole vigorously by plunging a clean 1/2" diameter sanitary bristle pipe brush in and out of the hole for two minutes while submerged.
4. Soak Stub Shaft (9) in acid sanitiser for 5 minutes, then scrub the blind tapped hole as described in step 3 above.
5. Rinse well with clean water and blow-dry the blind tapped hole with clean air.
6. Swab test the inside of the tapped hole to determine cleanliness.
7. Should the swab test fail, repeat steps 2 to 6 above until the swab test is passed.

Should swab testing continue to fail, or time is of the essence, install a new (spare) stub shaft (9).

---

## 5 Maintenance

Read the instructions carefully. The items refer to the parts list and service kits section.

Handle scrap correctly.

\* : Relates to the shaft seal.

### 5.3 Dismantling of pump/shaft seals

#### Step 1

1. Unscrew cap nuts (28) and remove washers (29) and pump casing (45).

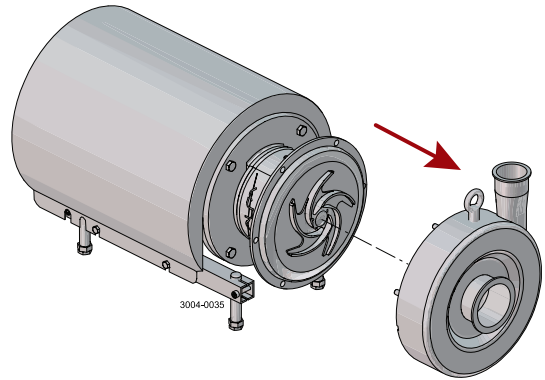

#### Step 2

Remove screw (14) and safety guard (15).

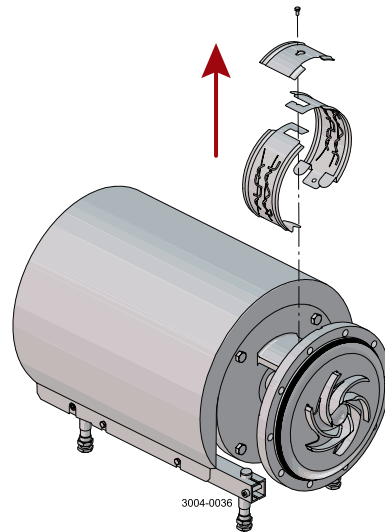

#### Step 3

##### Flushed shaft seal:

Unscrew fittings (23) using a spanner.

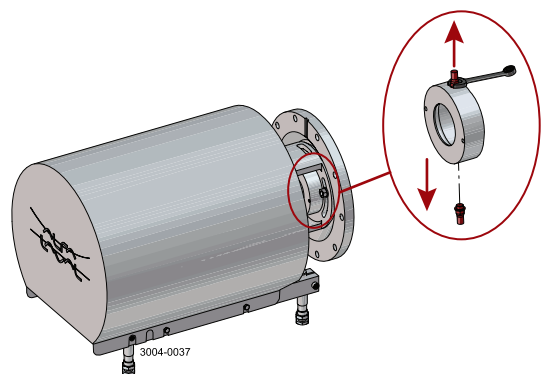

Read the instructions carefully. The items refer to the parts list and service kits section.

Handle scrap correctly.

\* : Relates to the shaft seal.

### Step 4

1. Remove impeller screw (41), if fitted, and pull off O-ring (42).
2. Remove impeller (39/40). If necessary, loosen the impeller by knocking gently on the impeller vanes.

\* Counterhold with a screwdriver!

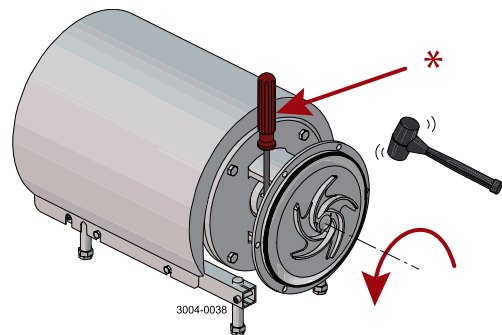

### Step 5

Pull out impeller (39/40) and the rotating part of the shaft seal.

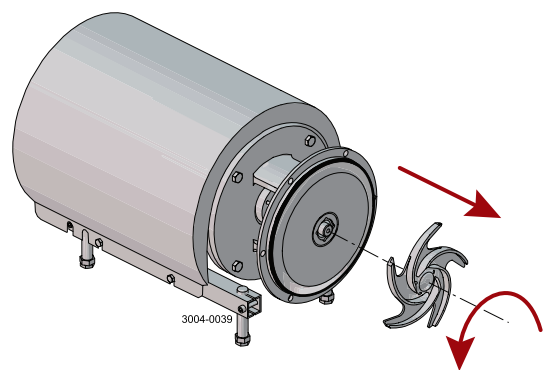

### Step 6

Remove space ring (33) and the rotating part of the shaft seal from impeller (39)/(40).

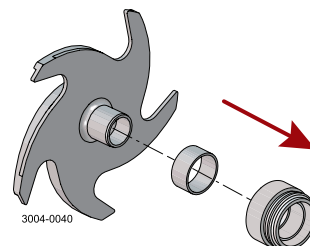

### Step 7

Separate rotating seal ring (34), quad rings (35, 38), support ring (36), guide ring (37) and washer (37) from rotating seal housing (37).

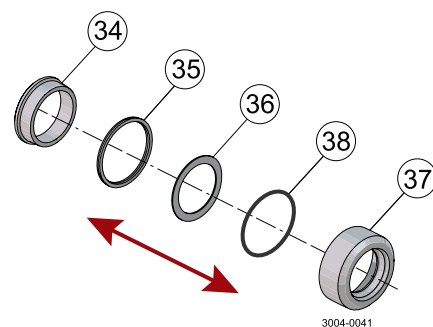

## 5 Maintenance

Read the instructions carefully. The items refer to the parts list and service kits section.

Handle scrap correctly.

\* : Relates to the shaft seal.

### Step 8

1. Unscrew nuts (19) and remove washers (20) and back plate (30).
2. Pull off joint ring (43) from the back plate.

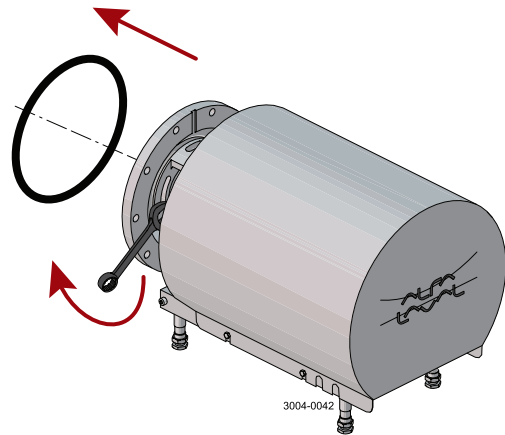

### Step 9

1. Pull out stationary seal ring (32).
2. Remove O-ring (31) from the stationary seal ring.

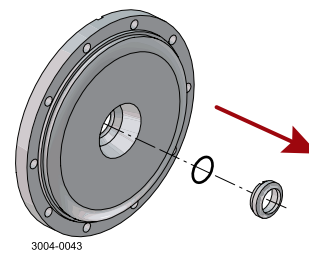

### Step 10

#### Flushed shaft seal

1. Remove screws (22) and seal housing (21).
2. Pull out lip seal (24) and O-ring (26) from the seal housing.
3. Slide off sleeve (27) from stub shaft (9).
4. Remove O-ring (25) from the sleeve.

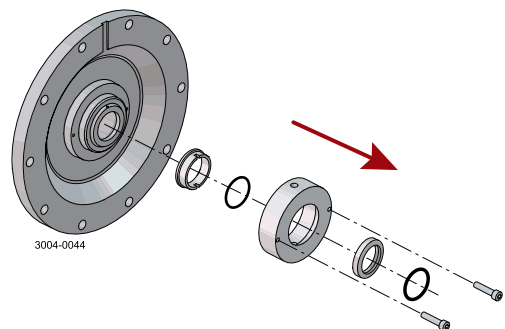



Read the instructions carefully. The items refer to the parts list and service kits section.

Handle scrap correctly.

\* : Relates to the shaft seal.

### Step 11

1. Remove shroud (2).
2. Unscrew nuts (7) and remove washers (6), screws (18) and adaptor (17).

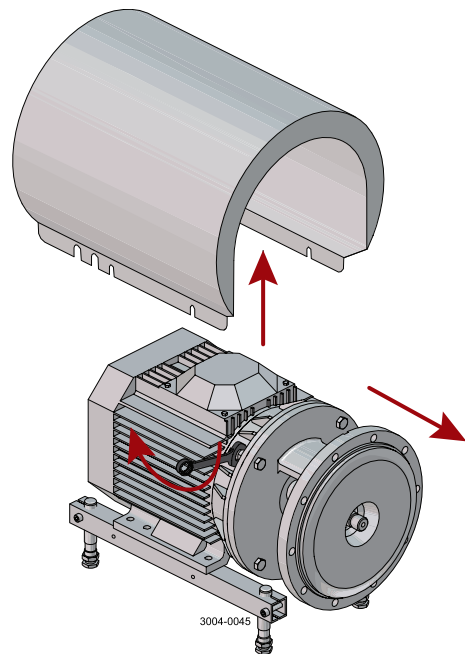

### Step 12

1. Loosen screws (13).
2. Slide off stub shaft (9) together with compression rings (12a+b).

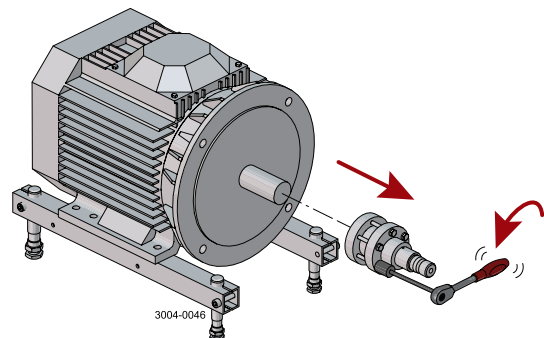

### Step 13

- Separate screws (13), washers (13a) and compression rings (12a+b).

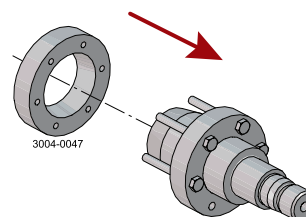

## 5 Maintenance

Read the instructions carefully. The items refer to the parts list and service kits section.

Handle scrap correctly.

\* : Relates to the shaft seal.

### 5.4 Assembly of pump/shaft seal

#### Step 1

LKHPF-70

For securing the best fixture to the motor shaft, ensure the following:

- Conical surfaces on the pump shaft and compression rings are applied with grease.
- No grease on the motor shaft.
- No grease on the inside diameter of the pump shaft.
- Screws for the compression rings are applied with grease.

1. Fit compression rings (12a, 12b), washers (13a) and screws (13) on stub shaft (9).
2. Slide the stub shaft onto the motor shaft.
3. Check the clearance between the end of the stub shaft and the motor flange (10-20 mm) (0.39" - 0.78").

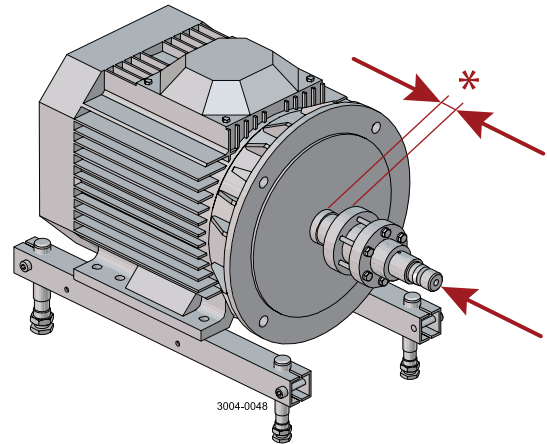

\* 10-20mm (0,39-0,78 Inch)

#### Step 2

1. Tighten screws (13) lightly and evenly.
2. Ensure that stub shaft (9) can be moved on the motor shaft.

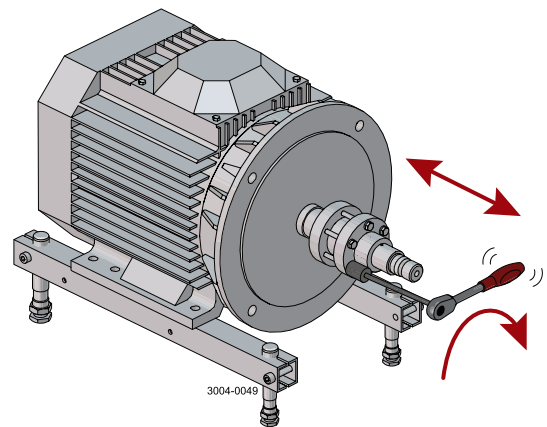

#### Step 3

Fit adaptor (17), screws (18), washers (6) and nuts (7) and tighten.

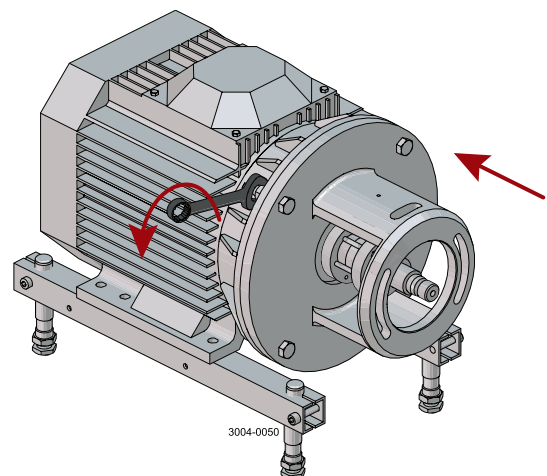

Read the instructions carefully. The items refer to the parts list and service kits section.

Handle scrap correctly.

\* : Relates to the shaft seal.

### Step 4

Fit back plate (30), washers (20) and nuts (19) and tighten.

Tightening torques: See addendum.

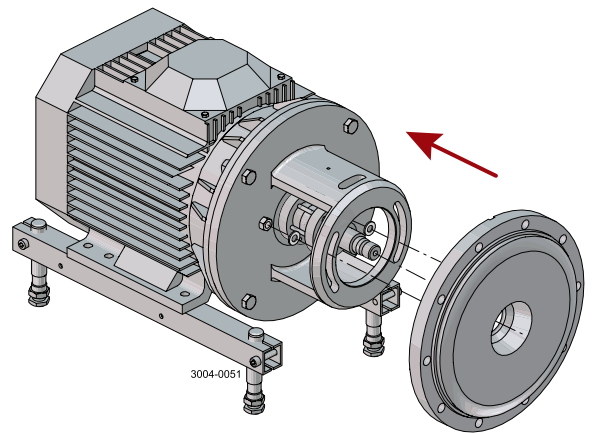

### Step 5

Assemble the rotating part of the shaft seal as shown above.

#### CAUTION!

Ensure that the driver in the rotating seal housing enters the notch in the rotating seal ring.

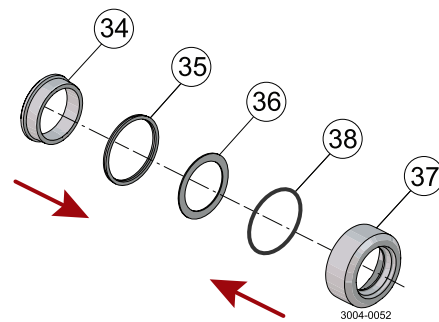

### Step 6

Fit the rotating part of the shaft seal and space ring (33) on impeller (39/40).

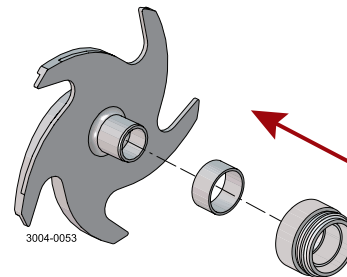

### Step 7

1. Fit impeller (39) or (40) on stub shaft (9) by rotating clockwise.
2. Ensure that the clearance between the impeller and back plate (30) is 1.0 mm (0.04"). The clearance can be adjusted by knocking gently with a plastic hammer.

\* 1.0 mm (0.039")

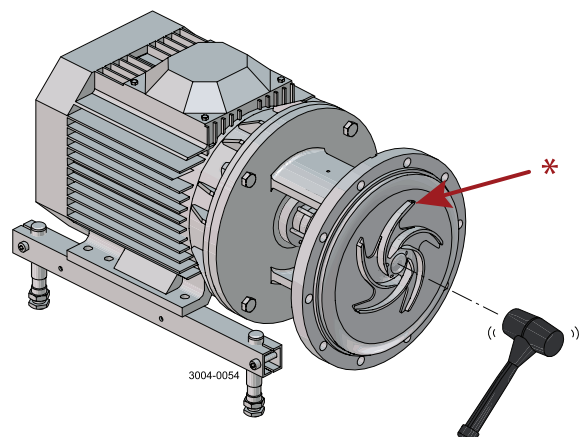

## 5 Maintenance

Read the instructions carefully. The items refer to the parts list and service kits section.

Handle scrap correctly.

\* : Relates to the shaft seal.

### Step 8

1. Remove impeller (39) and back plate (30).
2. Tighten screws (13) evenly to 15 Nm (11.06 lbf-ft).

\* Counterhold with a screwdriver

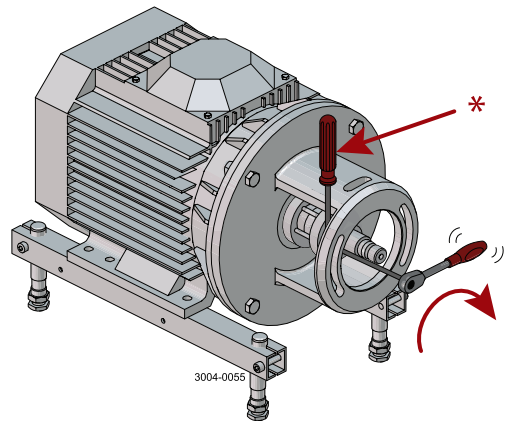

### Step 9

1. Slide O-ring (31) onto stationary seal ring (32).
2. Press the stationary seal ring into back plate (30).

#### CAUTION!

Ensure the two notch in the stationary seal ring enters into the two pins in the backplate.

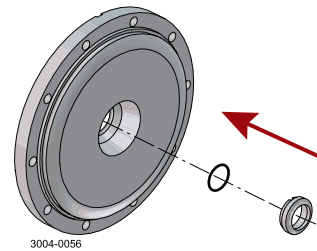

### Step 10

#### Flushed shaft seal:

1. Fit lip seal (24) and O-ring (26) in seal housing (21).
2. Fit the housing on back plate (30) and tighten the screws (22).
3. Slide sleeve (27) with O-ring (25) onto stub shaft (9).

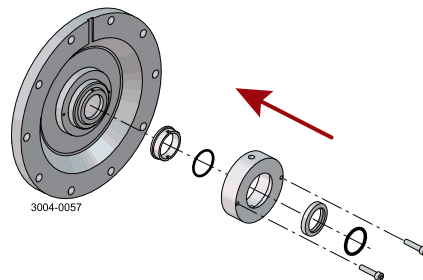

### Step 11

1. Fit back plate (30), washers (20) and nuts (19) and tighten.  
Tightening torques: See 6 Technical data
2. Fit O-ring (43) on the back plate.

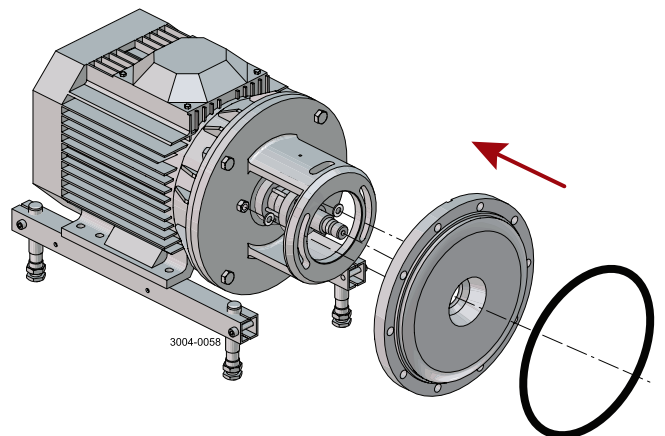

Read the instructions carefully. The items refer to the parts list and service kits section.

Handle scrap correctly.

\* : Relates to the shaft seal.

### Step 12

1. Lubricate impeller hub (39) with silicone grease or oil.
2. Screw the impeller onto stub shaft (9).
3. If used, fit O-ring (42) and impeller screw (41).

Tightening torque for impeller screw: 20 Nm (14,8 lbf-ft)

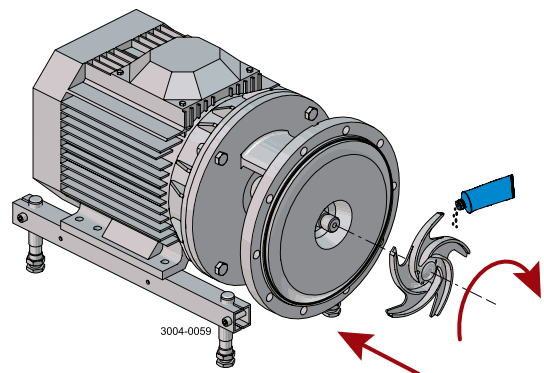

### Step 13

#### Flushed shaft seal

1. Screw fittings (23) into seal housing (21).
2. Tighten with a spanner.

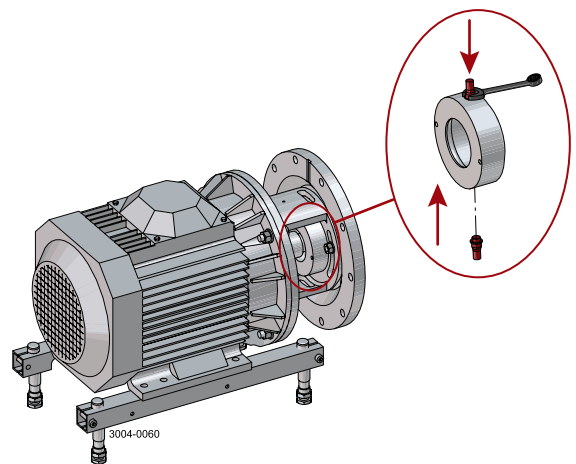

### Step 14

1. Fit pump casing (45).
2. Fit washers (29) and cap nuts (28) and tighten.

Note: Cap nuts must be tightened according to the torque values specified in chapter 6 Technical data

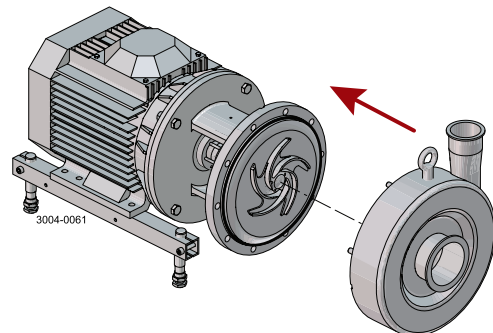

## 5 Maintenance

---

Read the instructions carefully. The items refer to the parts list and service kits section.

Handle scrap correctly.

\* : Relates to the shaft seal.

---

### Step 15

1. Mount shroud (2).

2. Position safety guard (15) and screw (14) and tighten.

If the pump is not supplied with flush connections, the holes in the adaptor must be covered by the guard.

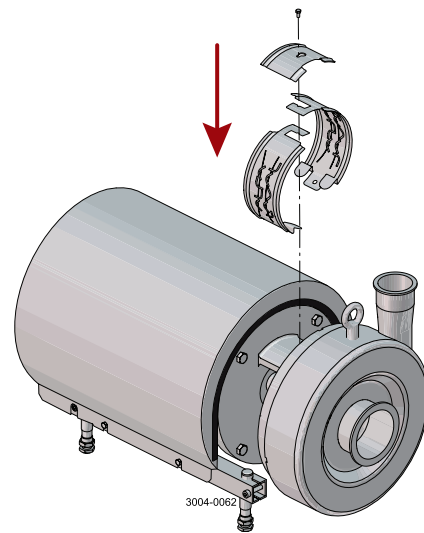

*It is important to observe the technical data during installation, operation and maintenance.  
Inform personnel about the technical data.*

## 6.1 Technical data

The LKHPF is a highly efficient and economical centrifugal pump, specially designed for high inlet pressure e.g. for use in filtration systems. The LKHPF pump meets the requirements of sanitary and gentle product treatment and chemical resistance, and is available in the following sizes, LKHPF-10, -20, -25, -35, -40, -45, -50, -60, -70. Read the instructions carefully. The larger pumps sizes are very heavy. Alfa Laval therefore recommends the use of a lifting crane when handling the pump.

Data			
Max. inlet pressure	4000 kPa	(40 bar)	
Max. inlet pressure (USA)	600 psi		
Temperature range	-10°C to +140°C	(14 to 284°F)	(EPDM)
Max. speed:	2 poles: 0,75 - 45 kW 2 poles: 55 - 110 kW	900 - 4000 rpm 900 - 3600 rpm	
Maximum product viscosity:	800 cP		
Materials			
Product wetted steel parts	AISI 316L		
Other steel parts	Stainless steel		
Finish	Semi-bright		
Product wetted seals	EPDM (standard)		
Other O-rings	EPDM		
Alternative seals	Nitrile (NBR), fluorinated rubber (FPM)		
Shaft seal			
Seal types	Single internal, flushed seal		
Max. temperature flush media	70°C		
Max. water pressure (flushed seal)	Normally atmospheric (max. 1 bar) (max. 14.5 psi)		
Water consumption (flushed seal)	0.25 - 0.5 l/min. (0.06-0.13 gal)		
Material, stationary seal ring	Silicon carbide		
Material, rotating seal ring	Silicon carbide		
Material, Quad/O-rings	EPDM (standard)		
Alternative material, O-rings	Nitrile (NBR), fluorinated rubber (FPM)		
Motor			
<b>IEC LKHPF</b>			
Standard foot-flanged motor according to IEC metric standard 2 poles = 3000/3600 rpm at 50/60 Hz IP55 (drain hole with labyrinth plug), insulation class F.			
Motor sizes (kW), 50 Hz	1.5 - 75 kW		
Motor sizes (kW), 60 Hz	1.75 - 86 kW		
<b>Nema LKHPF</b>			
For LKHPF-10 to -70: Standard foot-flanged motor according to NEMA standard. 2 pole = 3600 rpm at 60 Hz.			
Motor sizes (Hp), 60 Hz	7.5 - 100 Hp		

For further information, see PD sheet.

## 6 Technical data

---

*Relubrication interval 50 Hz (3000 rpm)/Relubrication interval 60 Hz (3600 rpm). (Vendor) quantity in Drive End/quantity in Non Drive End.*

---

### 6.2 Relubrication intervals

---

For recommended grease types and general maintenance follow the recommendations in the motor instruction manual.

For relubrication intervals see motor name plate.

For further information contact your local Alfa Laval Technical Support.

**Warning: Polyurea based grease (used on eg. LKH85 motors) must not be mixed with Lithium based grease or vice versa.**

---

### 6.3 Torque specifications

---

The table below specifies the tightening torques for the screws, bolts and nuts in this pump.

Always use the torques specified below if no other values are stated. This can be a matter of personal safety.

Size	Tightening torque	
	Nm	lbf-ft
M8	20	15
M10	40	30
M12	67	49
M14	110	81

---



## 6 Technical data

*Relubrication interval 50 Hz (3000 rpm)/Relubrication interval 60 Hz (3600 rpm). (Vendor) quantity in Drive End/quantity in Non Drive End.*

### 6.4 Weight (kg)

Pump Type: LKHPF

Size	90		112		132		160		180	200			250	
	2.2kW	4kW	5.5kW	7.5kW	11kW	15kW	18.5kW	22kW	30kW	37kW	45kW	55kW	75kW	
10	64	84												
20	68	88	105	119										
25		101	118	132	191	205								
35		101	119	133	192	206								
40				132	192	206	224	242						
45		103	120	134	194	208								
50			118	132	191	205	223	242						
60			120	134	193	207	225	244	352					
70			156	170	214	228	246	277	384	399	415	541	576	

Weight can vary depending of configuration. Weight is only to be seen as a reference value during handling, transporting and packaging.

## 6 Technical data

*Relubrication interval 50 Hz (3000 rpm)/Relubrication interval 60 Hz (3600 rpm). (Vendor) quantity in Drive End/quantity in Non Drive End.*

### 6.5 Noise emission

Pump Type	Sound pressure level (dBA)
LKH-5	60
LKH-10	69
LKH-15	72
LKH-20	70
LKH-25	74
LKH-35	71
LKH-40	75
LKH-45	70
LKH-50	75
LKH-60	77
LKH-70	88
LKH-75	79
LKH-85	86
LKH-90	75
LKH-112	70
LKH-113	69
LKH-114	68
LKH-122	75
LKH-123	77
LKH-124	80
SolidC-1	68
SolidC-2	72
SolidC-3	73
SolidC-4	72
MR-166	76
MR-185	82
MR-200	81
MR-300	82
GM	54
FM-OS	61

The above LKH noise levels are the same for LKH PF, LKH I, LKH UltraPure, LKH Evap and LKH Hex.  
The above SolidC noise levels are the same for SolidC UltraPure.

The noise measurements have been carried out with the original motor and shroud, at the approximate Best Efficiency Point (BEP), with the water at ambient temperature and at 50 Hz.

Very often the noise level generated by the flow through the process system (e.g. valves, pipes, tanks etc.) is much higher than that generated by the pump itself. Therefore, it is important to consider the noise levels of the whole system and take the necessary precautions with regard to personal safety, if required.

The drawing shows the LKHPF pump.  
The items refer to the parts lists in the following sections

## 7.1 LKHPF Filtration centrifugal pump for high inlet pressure

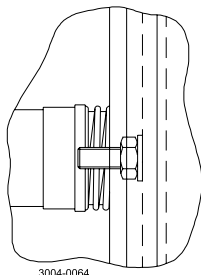
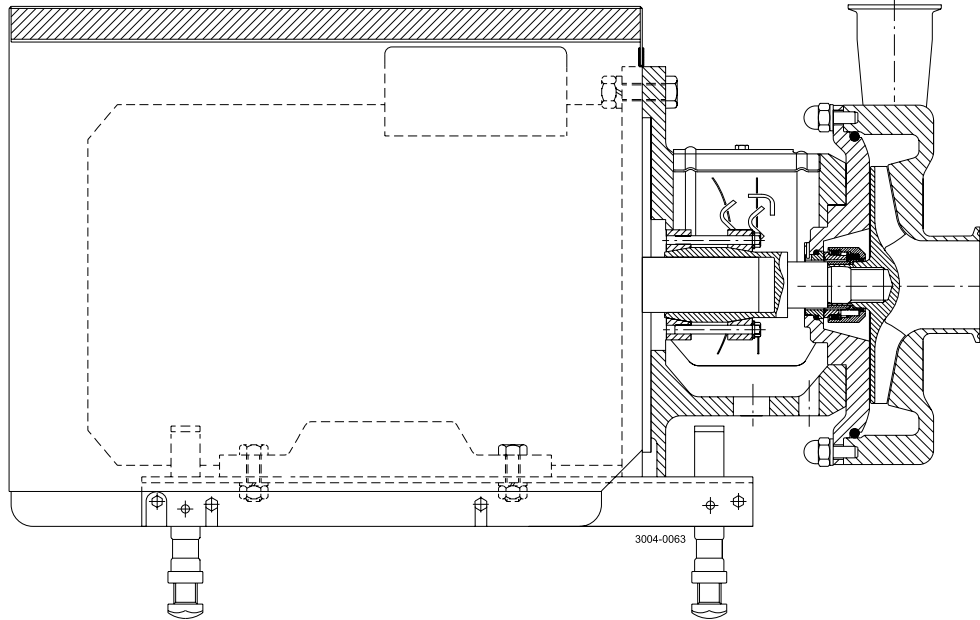

3004-0064  
Mounting of back plate to adaptor

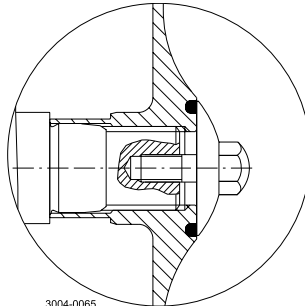

3004-0065  
Impeller screw

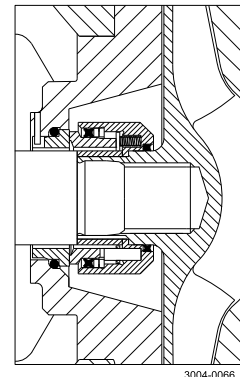

3004-0066  
Single shaft seal

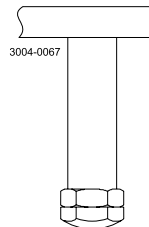

3004-0067  
Mounting of legs  
55-75 kW

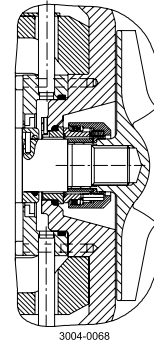

3004-0068  
Flushed shaft seal

## 7 Parts list and service kits

The drawing shows the LKHPF pump.

The items refer to the parts lists in the following sections

### 7.2 LKHPF - Wet end

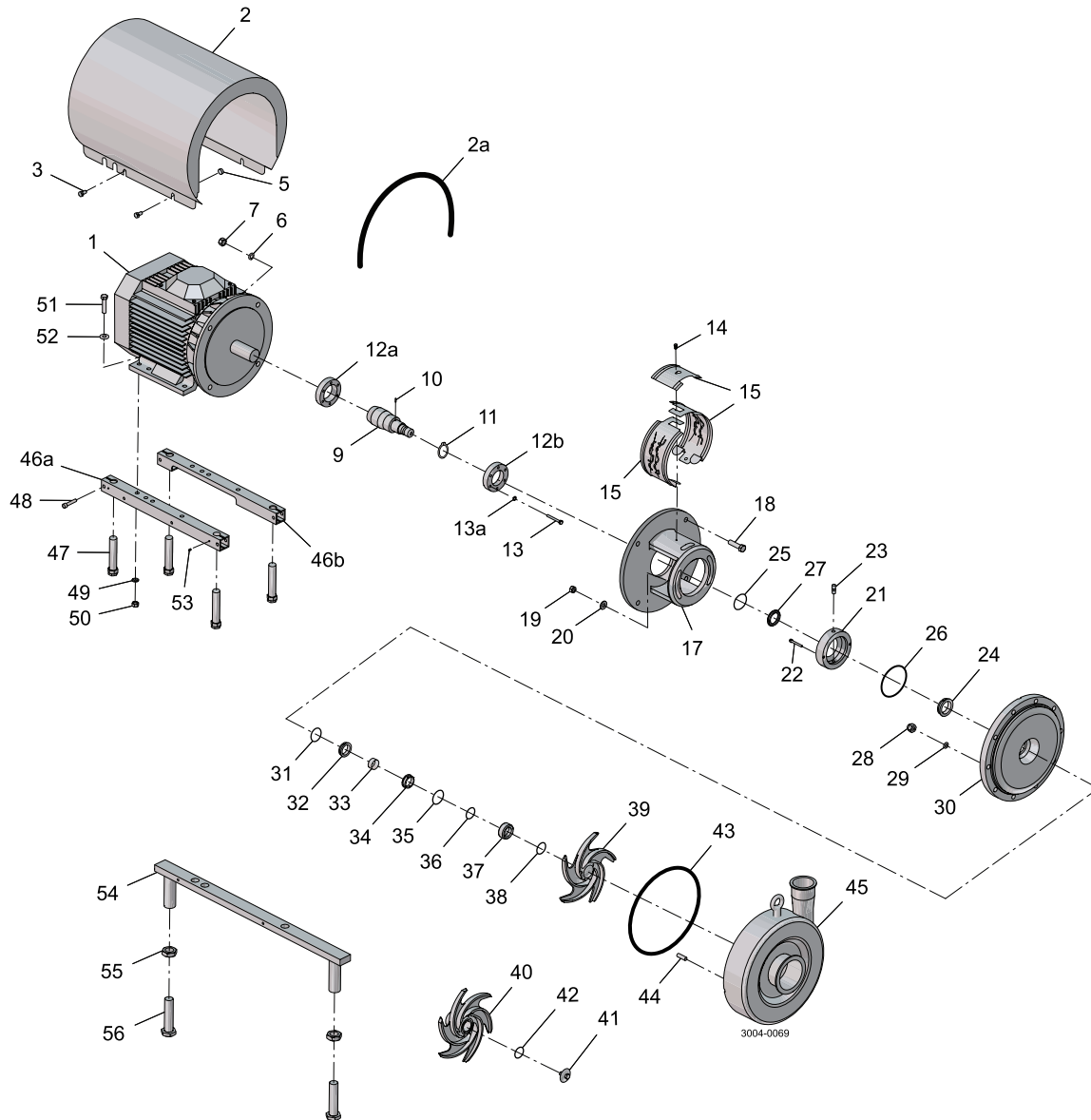

## 7 Parts list and service kits

The drawing shows the LKHPF pump.  
The items refer to the parts lists in the following sections

### Parts list

Pos.	Qty	Denomination
19	2	Nut
20	2	Washer
28	10	Cap nut
29	10	Washer
39	1	Impeller
40	1	Impeller for impeller screw
41	1	Impeller screw
42 ♦♦	1	O-ring
43 □♦○★	1	O-ring
44	10	Bolt
45	1	Pump casing compl.



## 7 Parts list and service kits

*The drawing shows the LKHPF pump.*

*The items refer to the parts lists in the following sections*

### Parts list

Pos.	Qty	Denomination
1	1	Motor ABB
2	1	Shroud
3	4	Screw
5	4	Distance sleeve
6	4	Washer for adaptor
7	4	Nut for adaptor
9	1	Shaft incl. pin
10	1	Connex pin
11	1	Retaining ring
12a	1	Compression ring with thread
12b	1	Compression ring without thread
13	6	Screw
13a	6	Washer
14	1	Screw for safety guard
15	1	Safety guard set
17	1	Adaptor
18	4	Screw for adaptor
46a	1	Support bar
46b	1	Support bar
47	4	Leg
48	4	Screw
49	4	Spring washer
50	4	Nut
51	4	Screw
52	4	Washer
53	4	Pivot screw
54	2	Leg bracket
55	4	Nut for leg
56	4	Screw for leg

## 7 Parts list and service kits

The drawing shows the LKHPF pump.

The items refer to the parts lists in the following sections

### 7.4 LKHPF – Shaft seals

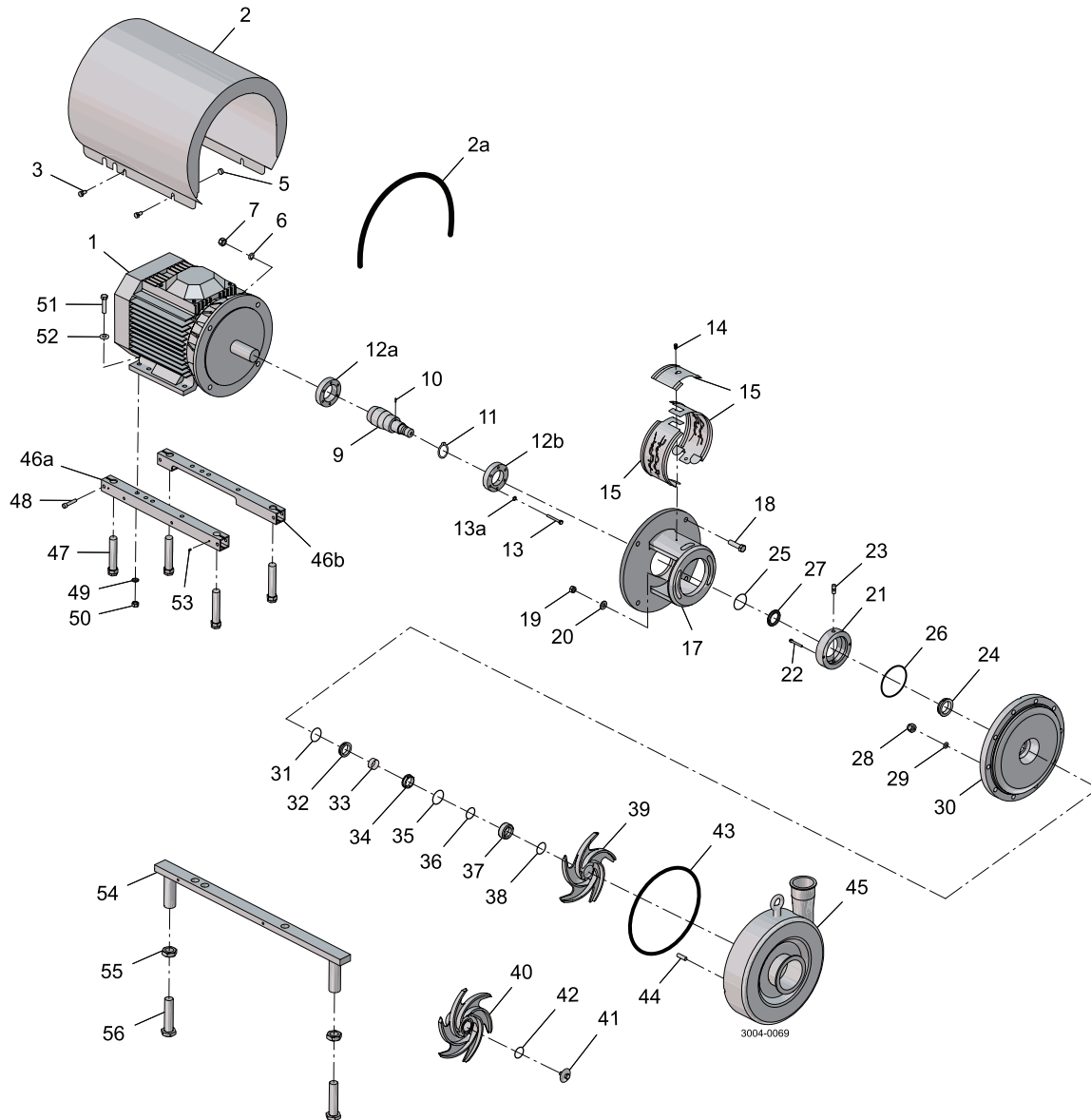



## 7 Parts list and service kits

The drawing shows the LKHPF pump.  
The items refer to the parts lists in the following sections

### Parts list

Pos.	Qty	Denomination
□♦		Shaft seal complete
○*		Shaft seal complete
21	1	Seal housing for flushed seal
22	2	Screw
23	2	Fittings
24	1	Lip seal
25	1	O-ring
26	1	O-ring
27	1	Sleeve
31	1	O-ring
32	1	Stationary seal ring
33	1	Spacing ring
34	1	Rotating seal ring
35	1	Quad ring/O-ring
36	1	PTFE support ring
37	1	Rotating seal housing
38	1	Quad ring/O-ring
57	1	Set of 8 springs for rotating sealhousing
	1	Set of 14 springs for rotating sealhousing

### Service kits

Denomination	EPDM	NBR	FPM
<b>Service kit for single shaft seal SiC/SiC</b>			
□ Service kit, SiC/SiC (LKHPF -10) .....	9611922139	9611922140	9611922141
□ Service kit, SiC/SiC (LKHPF -20) .....	9611922151	9611922152	9611922153
□ Service kit, SiC/SiC (LKHPF -25/35/45) .....	9611922194	9611922195	9611922196
□ Service kit, SiC/SiC (LKHPF -40/50/60) .....	9611922163	9611922164	9611922165
<b>Service kit for single shaft seal and impeller screw SiC/SiC</b>			
♦ Service kit, SiC/SiC (LKHPF -10) .....	9611922142	9611922143	9611922144
♦ Service kit, SiC/SiC (LKHPF -20) .....	9611922154	9611922155	9611922156
♦ Service kit, SiC/SiC (LKHPF -25/35/45) .....	9611922197	9611922198	9611922199
♦ Service kit, SiC/SiC (LKHPF -40/50/60) .....	9611922166	9611922167	9611922168
♦ Service kit, SiC/SiC (LKHPF -70) .....	9611922946	9611922947	9611922948
<b>Service kit for flushed shaft seal SiC/SiC</b>			
○ Service kit, SiC/SiC (LKHPF -10) .....	9611922145	9611922146	9611922147
○ Service kit, SiC/SiC (LKHPF -20) .....	9611922157	9611922158	9611922159
○ Service kit, SiC/SiC (LKHPF -25/35/45) .....	9611922200	9611922201	9611922202
○ Service kit, SiC/SiC (LKHPF -40/50/60) .....	9611922169	9611922170	9611922171
<b>Service kit for flushed shaft seal and impeller screw SiC/SiC</b>			
* Service kit, SiC/SiC (LKHPF -10) .....	9611922148	9611922149	9611922150
* Service kit, SiC/SiC (LKHPF -20) .....	9611922160	9611922161	9611922162
* Service kit, SiC/SiC (LKHPF -25/35/45) .....	9611922203	9611922204	9611922205
* Service kit, SiC/SiC (LKHPF -40/50/60) .....	9611922172	9611922173	9611922174
* Service kit, SiC/SiC (LKHPF -70) .....	9611922949	9611922950	9611922951

Parts marked with □♦○\* are included in the service kits. Recommended spare parts: Service kits.

Conversion single to flushed shaft seal : Please order Flushed service kit + pos. 21+22+23<sup>(900599/15)</sup>

**How to contact Alfa Laval**

Contact details for all countries are continually updated on our website.

Please visit [www.alfalaval.com](http://www.alfalaval.com) to access the information directly.

© Alfa Laval Corporate AB

This document and its contents is owned by Alfa Laval Corporate AB and protected by laws governing intellectual property and thereto related rights. It is the responsibility of the user of this document to comply with all applicable intellectual property laws. Without limiting any rights related to this document, no part of this document may be copied, reproduced or transmitted in any form or by any means (electronic, mechanical, photocopying, recording, or otherwise), or for any purpose, without the expressed permission of Alfa Laval Corporate AB. Alfa Laval Corporate AB will enforce its rights related to this document to the fullest extent of the law, including the seeking of criminal prosecution.