



## MBPX 810

### Medium-sized solids-ejecting centrifuge for the fermentation & biotech industries

The MBPX 810SGV-34CGL is a medium-sized unit in the range of centrifuges specially built for microbiological applications. The separation duties met with often require very high bowl speeds for an optimal performance in separation of solid particles with very small diameters.

#### Applications

The MBPX 810 is used for removing suspended solids with particle sizes of approx 0,5 to 500  $\mu\text{m}$  from a liquid having lower density than the solids. The solids content is usually in the range of 0,1 to 20% by volume. The main applications are bacteria separations, rDNA products, enzymes, cell cultures and vaccines. The maximum process capacity of the machine is 10  $\text{m}^3/\text{h}$

#### Features

The MBPX 810 centrifuge has a timer-triggered partial discharge system, meaning that only part of the bowl content is emptied during discharge. The volume of the discharge can be varied and takes place at full speed without any interruption of the feed. The bowl is mounted on a vertical spindle, driven by the horizontally mounted motor, via a worm gear. The flanged standard motor has a fixed coupling and is suitable for variable frequency drive. The drive system is splash-lubricated without any need for an external lubrication circuit. The built-in paring disc for the separated liquid eliminates the need for an external pump. It comes in two sizes for different flow ranges. The machine is equipped with nozzles for flushing above and below the bowl and in the sediment outlet.

#### Standard design

All liquid-wetted parts are made of high-grade stainless steel and liquid-wetted gaskets in FDA approved EPDM rubber. The machine is equipped with sensors monitoring vibration level and bowl speed. A cover switch prevents the start of the motor unless the machine top part has been properly mounted. The centrifuge is equipped with anchoring feet and



MBPX 810

vibration dampers. The tools for assembly and disassembly of the bowl are made of stainless steel.

#### Options

Two different disc stacks for different solids space volumes are available. The centrifuge can be supplied as a complete system with the centrifuge mounted on a fixed base frame. On this frame is included process piping for liquids entering and leaving the centrifuge and for service media. Typically an optional pump removes the solids phase. The built-in electrical system includes starter for variable frequency drive, a PLC unit and a pneumatic unit.

## Operating principles

The feed is introduced into the rotating centrifuge bowl via a stationary inlet pipe (1) and is accelerated in the distributor (2) before entering the disc stack (3). It is between the discs that the separation takes place. The liquid phase moves towards the center of the bowl, from where it is pumped out under pressure by means of a built-in paring disc (4).

The heavier solids phase is collected in the periphery of the bowl and is discharged at preset intervals through a cyclone. The solids discharge is achieved by a hydraulic system below the separation space in the bowl. When at pre-set intervals, the sliding bowl bottom (5) is forced to drop down, solids ports (6) are opened for the solids to be discharged.

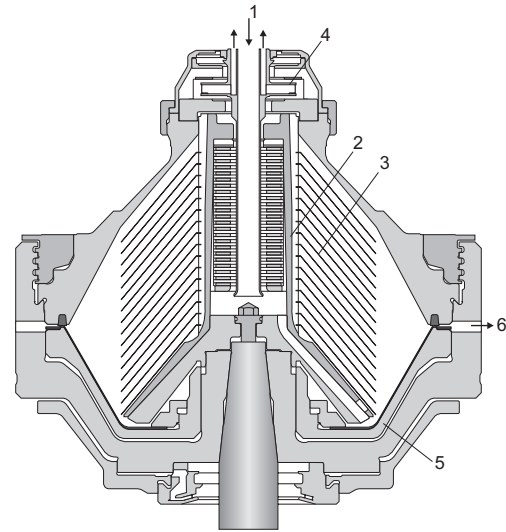

Typical bowl drawing for a solids ejecting centrifuge. Drawing details do not necessarily correspond to the centrifuge described.

## Utilities consumption

Power consumption	17 kW @ 10 m <sup>3</sup> /h (33 hp @ 110 US gpm)
Water consumption per discharge	1 l/h (0.26 US gallon)
Required discharge water pressure	max. 50 kPa (7 psi)
Jacket cooling water consumption	150 l/h

## Connections

Product inlet, outlet	DN 50 acc. to DIN 11851
Solids cyclone pipe	Clamp NW 63,5 acc. to ISO 2037

## Shipping data (approximate)

Centrifuge incl. bowl and motor	1,385 kg (3,060 lbs)
Bowl	300 kg (665 lbs)
Gross weight	2,000 kg (4,410 lbs)
Volume	4–5 m <sup>3</sup>

## Dimensions

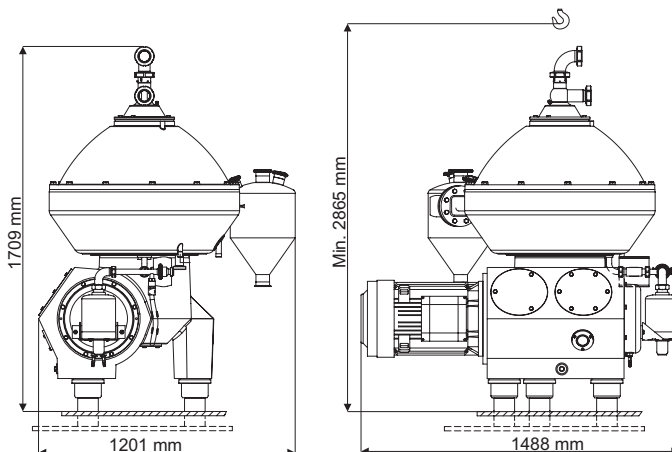

## Technical specifications

Throughput capacity	max. 10 m <sup>3</sup> /h (44 US gpm)
Solids handling capacity	max. 360/540 l/h
Feed temperature range	0–100 °C (32–212 °F)
Bowl speed	7,488 rpm
Bowl volume	15 l
Solids space volume	6,8/9,4 l
Motor speed, synchronous 60 Hz	1,800 rpm
Motor power installed	22/25 kW (30/33 hp)
Starting time, min/max	8–10 min
Stopping time without brake (average)	45 min
Feed pressure required	0–50 kPa (0–7 psi)
Outlet pressure available	600–800 kPa (80–110 psi)
Sound pressure	79 dB (A) <sup>1)</sup>
Overhead hoist capacity	900 kg

<sup>1)</sup> In compliance with EN ISO 4871.

## Material data

Bowl body	EN 1.4418
Bowl hood and lock ring	EN 1.4418
Distributor	EN 1.4401 UNS 31600
Solids cover and frame hood	EN 1.4401 UNS 31600
In & outlet parts	EN 1.4401 UNS 31600
Frame bottom part	Cast iron
Gaskets and O-rings	EPDM rubber acc. to FDA 21 CFR
Bowl tools	EN 1.4401 UNS 31600

## How to contact Alfa Laval

Up-to-date Alfa Laval contact details for all countries are always available on our website at [www.alfalaval.com](http://www.alfalaval.com)