



PX 65 & PX 65EX

Medium-capacity disc stack centrifuge for fats and oils refining

The Alfa Laval range of centrifuges for the vegetable oil and animal fat refining industries is continuously modernized to take advantage of developments in materials, mechanical design and fluid dynamics. The PX 65/65EX is a medium-sized machine in this range of centrifuges.

Applications

Continuous degumming, neutralizing, dewaxing and washing of fatty oils, such as vegetable oils, lard, tallow and fish oil.

Performance

The table below shows nominal capacities. Actual throughputs vary according to the type of oil and fat to be treated.

Degumming, neutralization, washing	10,500 kg/h
Dewaxing	6,250 kg/h

Standard design

The machine consists of a frame with a base that contains a horizontal drive shaft, worm gear, lubricating oil bath and hollow vertical bowl spindle. The bowl is fixed on top of the spindle, inside the space formed by the upper part of the frame, the solids collecting cover and the frame hood. The hood carries the liquid discharge system.

All parts in contact with the process liquid are made of stainless steel.

The bowl is of the solids ejecting disc type, with an automatic hydraulic operating system for intermittent solids discharge.

The standard electric motor is suitable for variable frequency drive.

Design features

The PX 65/65EX is based on a unique, semi-hermetic design concept. The hermetic, bottom-fed inlet ensures a gentle, non-destructive acceleration of the feedstock up to full bowl speed.

The flow area for the feedstock is designed to minimize inlet pressure drop. The outlets on the heavy and light phases are open, reducing the pressure drop across the separator. The feed-pressure requirement of the machine is therefore low.

The outlets are equipped with stationary paring devices for removal of the different phases. The paring disc on the light phase is fixed, while the paring tubes on the heavy phase are adjustable.



PX 65 complete with motor

By adjusting a positioner on the heavy phase outlet, the operator can reduce or enlarge the paring diameter of the paring tubes. This patented innovation makes it possible to adjust the position of the separation interface during operation, facilitating optimal separation.

With the working environment in mind, the PX 65/65EX is designed to operate at low noise levels. This is achieved by means of a rubber-damped bearing assembly, jacketed frame and an outer bowl design, which is engineered for low wind noise.

Basic executions

PX 65 for non-explosive environments.

PX 65EX for ATEX zone 2.

Standard equipment

Each PX 65/65EX comes complete with control unit, electric motor, inlet and outlet connections, auxiliary equipment, a spare parts kit and a set of tools.

Operating principles

The oil to be separated is fed (1) into the separator bowl from the bottom through a hollow spindle (2) and enters the disc stack (3).

The heavy phase and heavy sludge are forced towards the periphery of the bowl, while the light phase flows towards the centre of the bowl, from where it is pumped out (4) for further processing. The heavy phase is led over a top disc (5) into a chamber where an adjustable paring device pumps it out of the separator (6).

Sludge collects in the sludge space (7) and is discharged intermittently and automatically. The discharge is achieved by a hydraulic system, which at preset suitable intervals forces the sliding bowl bottom (8) to drop down, thus opening the sludge ports at the bowl periphery. The sludge is collected in the frame and leaves the centrifuge via a cyclone.

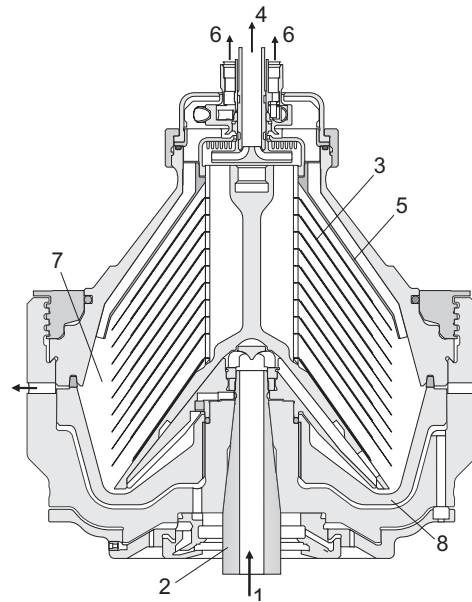

Typical bowl drawing for solids ejecting hermetic centrifuge. Drawing details do not necessarily correspond to the centrifuge described.

Material data

Bowl body, hood and lock ring	s.s. 1.4418 UNS
Frame top part and hood	s.s. 1.4401 UNS S31600
Frame bottom part	Cast iron, clad with s.s. 1.4301 UNS 30400
Gaskets and O-rings	Nitrile rubber

Shipping data (approximate)

Separator incl. bowl and motor	1,425 kg (3,140 lbs)
Bowl	310 kg (685 lbs)
Gross weight	1,750 kg (3,860 lbs)
Volume	5 m ³ (177 cft)

Technical specifications

Throughput capacity	max. 15 m ³ /h (66 US gpm)
Bowl speed, synchronous	7,450 rpm
Bowl volume	15 l (3.97 US gal)
Sludge space	4.6 l (1.2 US gal)
Motor power installed	25 kW (33.5 HP)
Inlet pressure at 15 m ³ /h (66 US gpm)	0 kPa
Sound pressure level	76 dB (A)
Overhead hoist lifting capacity	min. 900 kg (1,984 lbs)

ATEX design codes

EX II 3 G T4 X for zone 2

Dimensions

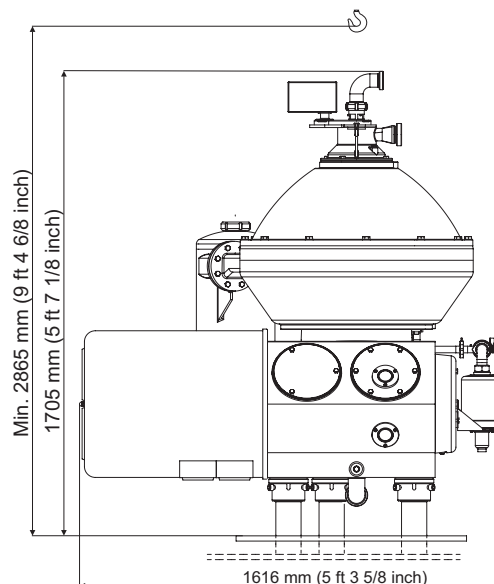
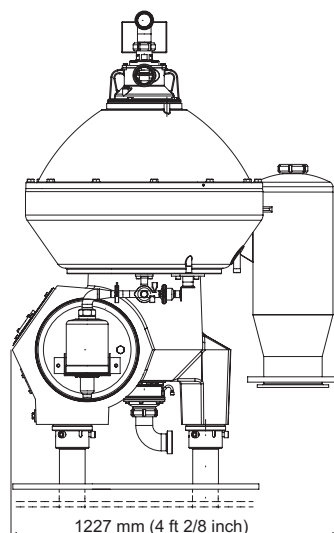

PCHS00087EN 1105

Alfa Laval reserves the right to change specifications without prior notification.

How to contact Alfa Laval

Up-to-date Alfa Laval contact details for all countries are always available on our website at www.alfalaval.com