

Alfa Laval MB 20

Disc stack separation system for biopharma and fermentation processing

Introduction

For more than 100 years, Alfa Laval has been supplying separators for various industries. Today, Alfa Laval has the most complete and diverse offering of separators – each fully optimized for its specific duty and supplied with all auxiliary systems and key components.

The use of separators in biopharma and fermentation processes is not new. Based on long experience in these industries, Alfa Laval separators are specially designed for the requirements and demands of this industry.

Application

The MB 20 is a high-performance separation system, specifically designed and optimized for biopharma applications. It is used for removing suspended solids from a liquid having lower density than the solids. Applications involving liquids with tendency to foam generation or with products sensitive to shear forces can also take advantage of the hermetic feature offered by these machines.

Typical separation applications are the following:

- Bacteria separation
- Probiotics separation
- rDNA production
- Cell cultures separation
- Vaccines production
- Bio-based processing

Benefits

- Scalability to larger production volume
- Gentle treatment of the product
- Easy to operate
- Plug-and-play installation
- Small footprint
- Sanitary design
- Low temperature pick up through the machine

Design

The pilot scale MB 20 system consists of a skid mounted disc stack separator with integrated direct drive, process & service liquid components, and electrical & control system with touch screen HMI.

The disc stack separator is based on Alfa Laval's fully hermetic concept with bottom fed inlet. This design is ideal for



gentle processing of shear sensitive particles, preventing formation of emulsions, and preventing lyses of cells. The system also provides separation at the lowest possible power consumption. As the hermetic design prevents air entrainment, any process issues caused by air / oxygen pick-up is minimized. Moreover the hermetic design together with discharge functionality with fixed volumes ensure efficient cleaning (CIP) of the product wetted surfaces.

All metal parts in contact with the process liquid are made of stainless steel. The bowl shell is made from corrosion resistant duplex stainless steel and all liquid-wetted gaskets are made of FDA or USP Class VI approved EPDM.

The separation system is available with main connections as sanitary tri-clamps. Special attention has been paid to a hygienic requirement and effective CIP with external bowl flushing.

The electric motor is suitable for variable frequency drive. The drive system is direct drive with pre lubricated bearings. The tools for assembly and disassembly of the bowl are made of stainless steel.

The machine is equipped with sensors monitoring vibration level, bowl speed and bearing temperatures.

All components are skid mounted to facilitate "Plug and Play" installation, which results in a small footprint.

The control system includes a PLC and a user-friendly HMI to monitor and control the separation process parameters.

The system can be connected to remote operation.

Scope of supply

The MB 20 skid mounted system includes the following main components:

- Disc stack separator
- Process & service liquid unit:
 - Valves, instruments and other components
 - Magnetic Flow meter
 - Sight glasses
 - Sample valves
 - Timer triggered solids discharge function
- Electrical & control system (Siemens or Allen Bradley):
 - Control cabinet with PLC and HMI
 - Motor starter cabinet with VFD
- Commissioning spares
- Set of special tools (stainless steel)
- Documentation

Options

- Turbidity triggered solids discharge function
- Mass flow meter
- Feed pump
- Service options
 - Commissioning
 - Operators training
 - Basic service agreement

Working principle

The process & service liquid unit monitors and regulates the flow and pressure of the feed and utility liquids in and out of the separator. The process liquid is continuously fed from the bottom into the bowl through the hollow spindle (1), which assures gentle acceleration. Separation takes place in a solids-ejecting centrifuge bowl, between the discs (3). The light phase moves towards the centre and is discharged (5). The heavy solids phase is collected at the periphery and is ejected from the bowl intermittently at full operating speed. During production mode the bowl bottom is hydraulically pressed into a closed position, ensuring a tight seal against the bowl hood. Periodically, at predetermined intervals, the sliding bowl bottom (6) is lowered hydraulically and waste residue is evacuated through the discharge ports (7). The bowl is then closed again by hydraulic action. The intermittent discharge is done without shutting off the feed of cleaning liquid. Mechanical seals on the inlet and outlet maintain a full hermetic condition.

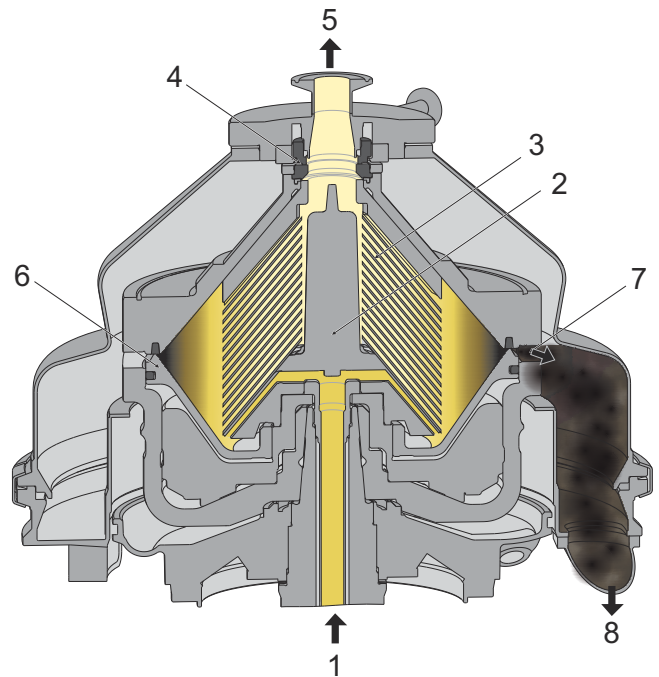

Typical bowl drawing for a bottom fed separator. The details illustrated do not necessarily correspond to the separator described.

1. Inlet
2. Distributor
3. Disc stack
4. Hermetic seal
5. Light liquid phase outlet
6. Sliding bowl bottom
7. Solids discharge ports
8. Solids outlet

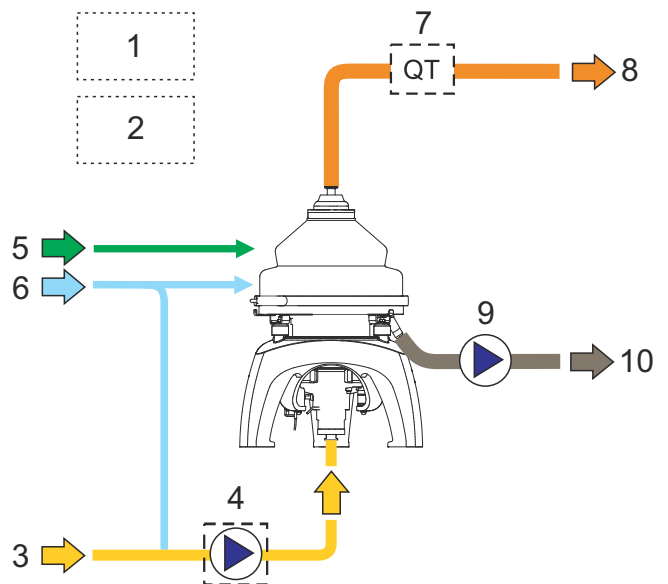

Typical flow chart of a separator system. The details may differ based on the actual order.

1. Control cabinet
2. Starter cabinet
3. Product inlet
4. Feed pump (optional)
5. Cooling water
6. Operating water
7. Turbidity meter (optional)
8. Liquid phase outlet

- 9. Sludge pump
- 10. Solids outlet

Technical data

Performance data

Max capacity ¹	1000 litre/h (4.4 US gpm)
Maximum power consumptions	2.2 kW (2.9 HP)

¹ Actual capacities depend on operating conditions

Connections

Feed inlet	Tri Clamps, ½ inch
Light phase	Tri Clamps, ½ inch
Solids outlet	Tri Clamps, ½ inch

Material data

Bowl body	Stainless steel EN 1.4462
Frame top part	Stainless steel 316, EN 1.4401
Frame bottom part	Stainless steel 316, EN 1.4401
Skid frame and cabinet	Stainless steel AISI 304
Piping	Stainless steel AISI 316L
Gaskets (product wetted)	EPDM FDA, EPDM USP VI

Weights

System incl. separator without bowl	393 kg (866 lbs)
Bowl	40 kg (88 lbs)

Dimensional drawing

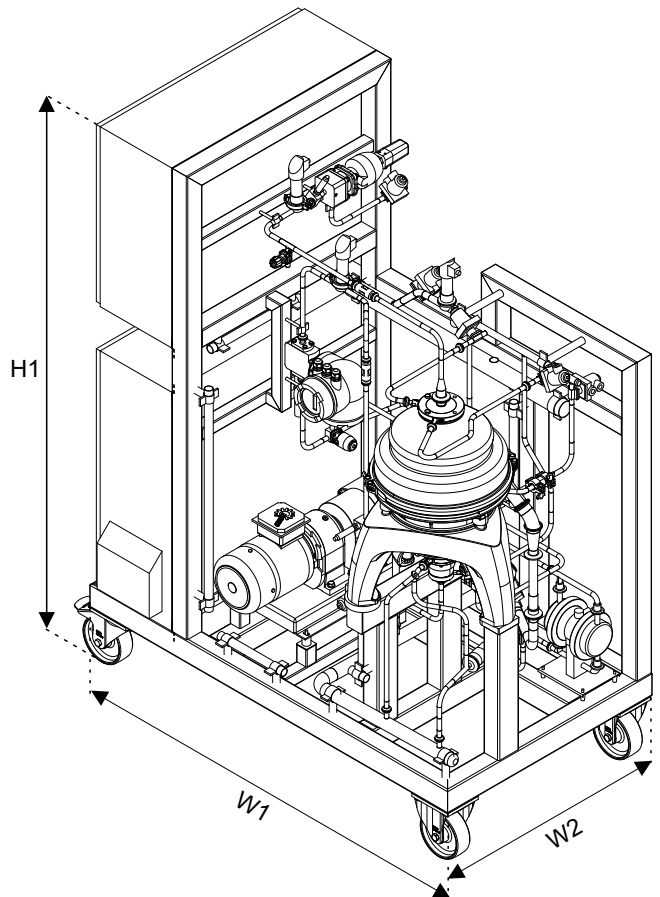

Dimensions

H1	1850 mm (6 ft)
W1	1400 mm (4.6 ft)
W2	800 mm (2.6 ft)

This document and its contents are subject to copyrights and other intellectual property rights owned by Alfa Laval AB (publ) or any of its affiliates (jointly "Alfa Laval"). No part of this document may be copied, re-produced or transmitted in any form or by any means, or for any purpose, without Alfa Laval's prior express written permission. Information and services provided in this document are made as a benefit and service to the user, and no representations or warranties are made about the accuracy or suitability of this information and these services for any purpose. All rights are reserved.

How to contact Alfa Laval

Up-to-date Alfa Laval contact details for all countries are always available on our website at www.alfalaval.com